

# Hisense

Qingdao Hisense HVAC Equipment Co., Ltd.  
Hisense Tower, Qingdao, China

<http://www.hisense-vrf.com> [export@hisensehitachi.com](mailto:export@hisensehitachi.com) [@HisenseVRFGlobal](#) [Hisense VRF](#) [Hisense VRF](#)



★ Design and specifications are subject to change without notice. Pictures and diagrams are for reference only and are subject to change without notice.  
All rights reserved by Qingdao Hisense HVAC Equipment Co.,Ltd.

## Hisense VRF



### Hi-FLEXi S mavo

Cooling Only



Reimagine your solution



## Hisense SINCE 1969

Hisense Group is a well-known large-scale electronic information industry group company. Based on technology and focusing on innovation-oriented culture, its scientific and efficient technological innovation system makes Hisense always be at the forefront of the counterparts. Hisense brand family has continued to grow with Toshiba, Gorenje and ASKO. Multi-brand operations will be defined according to Group's Strategy Management Department.

SINCE 1969

## BUSINESS LAYOUT

### Multimedia

- TV and Display Devices
- Internet TV Operation
- Mobile Communication Devices
- Optical Communication Devices
- Chip

### Household Appliances

- Refrigerator
- Freezer
- Air-conditioner
- Washing Machine
- Kitchen Appliance

### IT Smart Systems

- Smart City
- Smart Community
- Smart Transportation
- Smart Business
- Medical Electronic Devices
- Smart Home System and Service

### Real Estate & Modern Services

- Real Estate
- High-end Plaza Chains
- Mould Design and Manufacturing
- Finance
- Trade

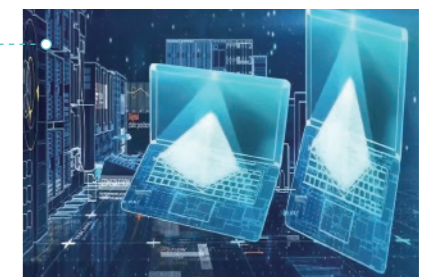

# GLOBAL VOICE

Hisense has started a long-term sports marketing strategy to increase brand awareness worldwide. After the successful sponsorship of **UEFA EURO 2016** and **2018 FIFA WORLD CUP**, Hisense has made clear its focus on football. And now, Hisense becomes the official partner of **UEFA EURO 2020**.



Official Sponsor of the Australian Open

Title Sponsor of Hisense 300 NASCAR Xfinity Series and Team Sponsor of Joe Gibbs Racing

Team Supplier to Red Bull Racing



Official Partner of UEFA EURO 2016

Official Sponsor of the 2018 FIFA World Cup

Official Partner of UEFA EURO 2020



# Hisense VRF MANUFACTURING BASE

Qingdao Hisense HVAC Equipment Co., Ltd. is a wholly owned subsidiary of Qingdao Hisense Hitachi Air-conditioning Systems Co., Ltd., who is a joint-venture of Hisense and Hitachi (changed to Johnson Control Hitachi in 2015) and was established in 2003.

It integrates technology development for commercial and residential central air conditioners, product manufacturing, marketing and service as a whole. With the full support of all the shareholders such as Hisense and Johnson Control Hitachi, Hisense VRF is committed to becoming the market leader in the industry.

With solid technical innovation strength, Hisense VRF has participated in the formulation and revision of 38 national standards, industry standards and association standards, and has 659 authorized patents in the field of CAC and heat pump products. Since 2008, 58 technologies have reached the advanced level through authorized certification. Now Hisense VRF has become a leading CAC enterprise in China.

Note: The above data is valid before Dec. 31th, 2020.



# Contents

05	High Reliability	33	Outdoor Unit
13	High Efficiency	53	Indoor Unit
19	Comfort	87	Control System
27	Flexibility	99	Accessory

# Brand-new Upgrade

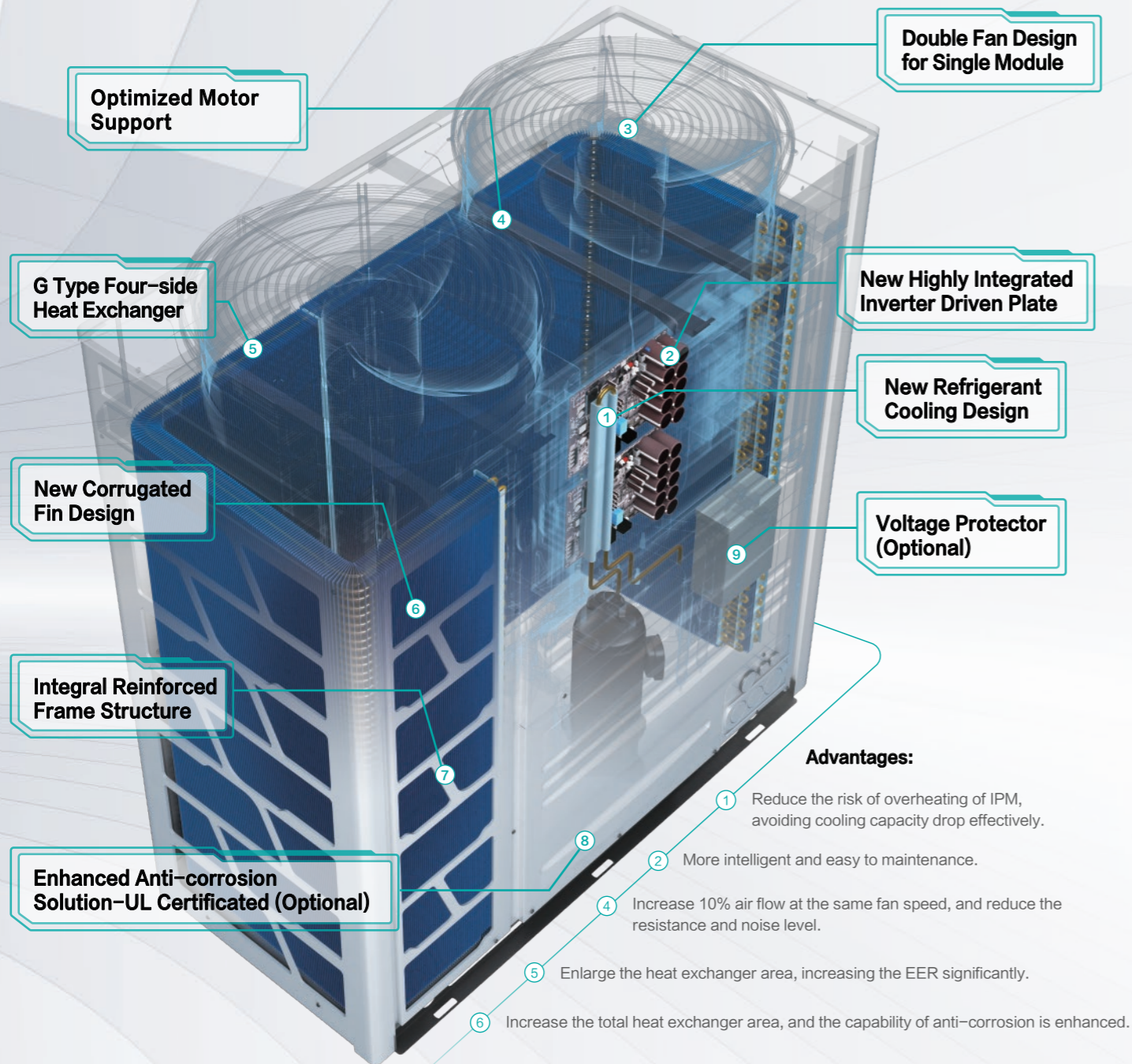

## New Structure

New structure with integrated sheet metal shell is developed. While achieving more beautiful appearance, the frame is more firm and anti-impact. Meanwhile, the G type four-side heat exchanger is newly applied.

### Capacity of Single Module Increased up to 28HP

For the single module (from 14HP to 28HP), new four-side all round heat exchanger and double-fan design ensure a good heat exchange performance. New single modules ranging from 18HP to 28HP are available, and combined modules' capacity is increased up to 112HP, which can better meet the demands of large projects.



### Compact Body Design, Reduced Footprint

There is less limit of installation thanks to its compact body design. Taking 12HP single module as an example, the footprint is reduced by 20%. While for the unit of 28HP, the footprint is reduced by 34%.



## Enhanced EER

Through the optimization and upgrading of key components such as compressor and heat exchanger, as well as the state-of-the-art technologies application, the overall energy efficiency of S mavo series cooling only unit has been increased by up to 10%. What's more, a new high-efficiency lineup is available through optimized module combination, ensuring a higher efficiency operation.

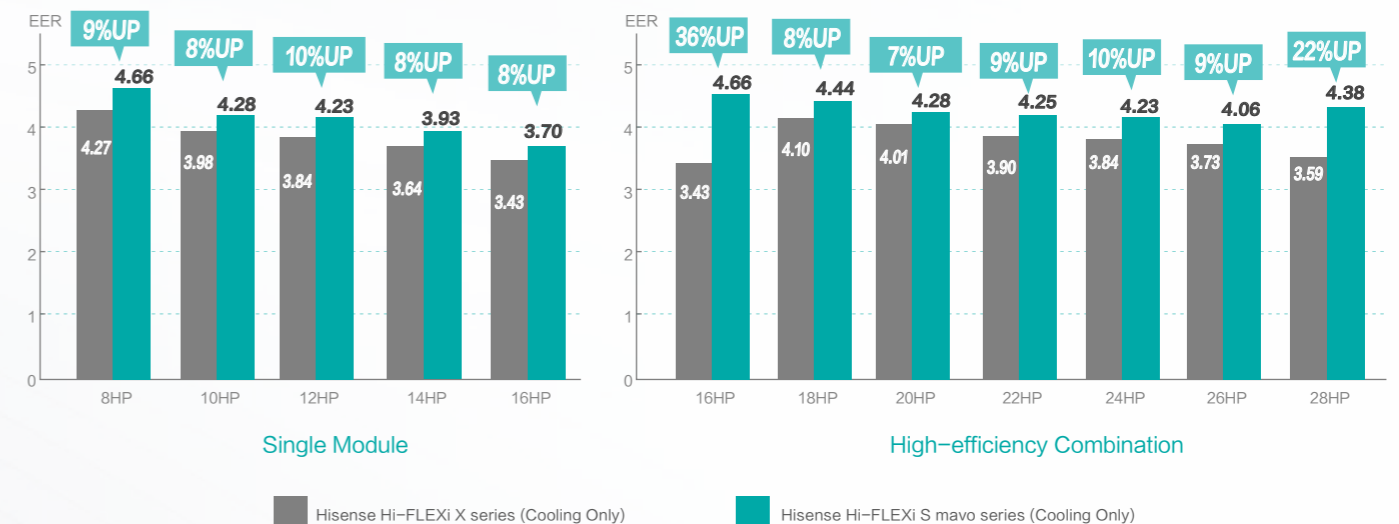

# High Reliability

COOLING ONLY



- Patented 360° Fitted Refrigerant Cooling Technology
- Oil Balance
- Double Rotative Operation
- Triple Backup Operation
- Enhanced Anti-corrosion Solution (Optional)
- Wider Operation Temperature

- Automatic Restart
- Insect Protection of Electrical Box
- Voltage Protector Reserved (Optional)
- Independent Maintenance of Indoor Units
- Condensate Water Leakage Protection

COOLING ONLY

## Patented 360° Fitted Refrigerant Cooling Technology

Hi-FLEXi S mavo cooling only unit uses refrigerant cooling technology to cool the electrical control box. It overcomes the poor heat dissipation and high ambient temperature issues to maintain efficient operation even at harsh environment. Compared with air-cooled technology, the temperature inside the electrical box can be reduced by up to 20%\*. Moreover, the refrigerant cooling kit adds a temperature sensor, which could be more precise to control the refrigerant cooling temperature and ensure the whole reliability.

\* The data is based on the S mavo cooling only unit under low fan speed operation.

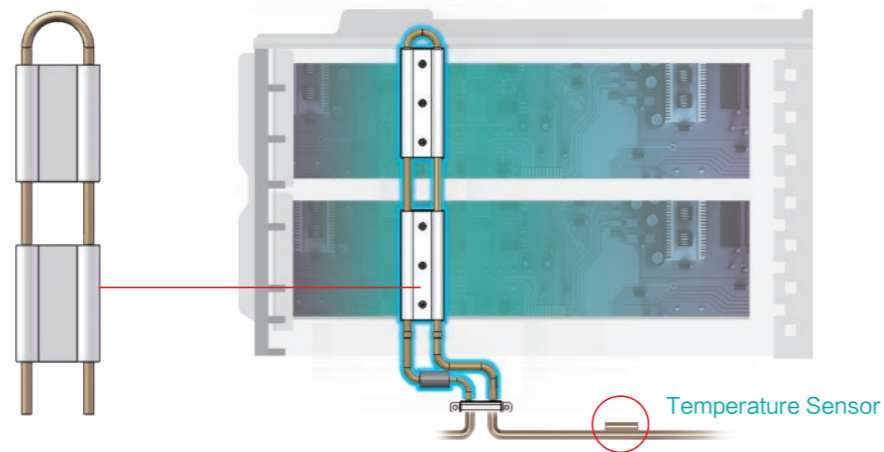

## Oil Balance

### Oil Return

The accumulator adopts pore tube oil return technology with a built-in fine strainer, which not only ensures oil balance between compressors within one module, but also plays an important role in the oil balance between modules. Besides this, the system implements oil-return function based on compressor frequency and corresponding operation time. The oil-return takes 60 seconds and can return to previous condition when finished.

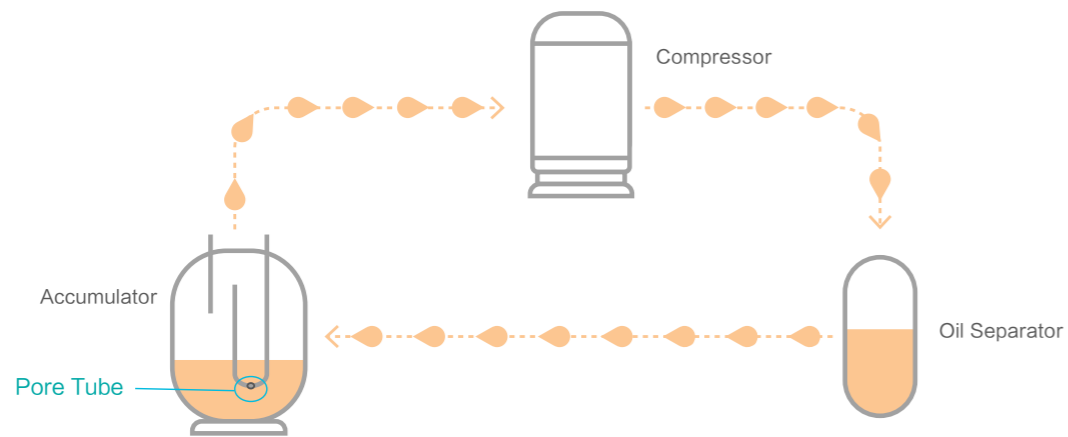

## Oil Separation

First-stage oil separation is realized through efficient oil separation structure inside the high-pressure-chamber compressor. Only a small amount of oil is brought out of the compressor.

During the second-stage oil separation, the small amount of oil discharged from compressor is separated by a large-capacity, high-efficiency centrifugal oil separator, with efficiency over 99%.

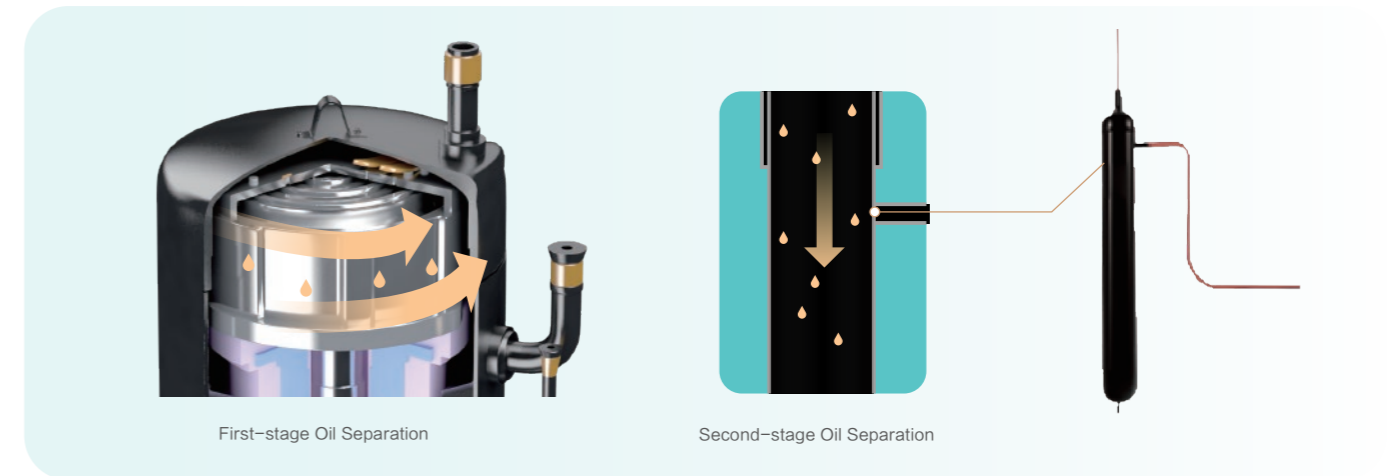

## Double Rotative Operation

The double rotative operation technology will effectively balance the operation time between the modules and balance the time between the compressors of the single module, which prevent the occurrence of individual unit overworked and hence extending the overall operating life of the overall system.

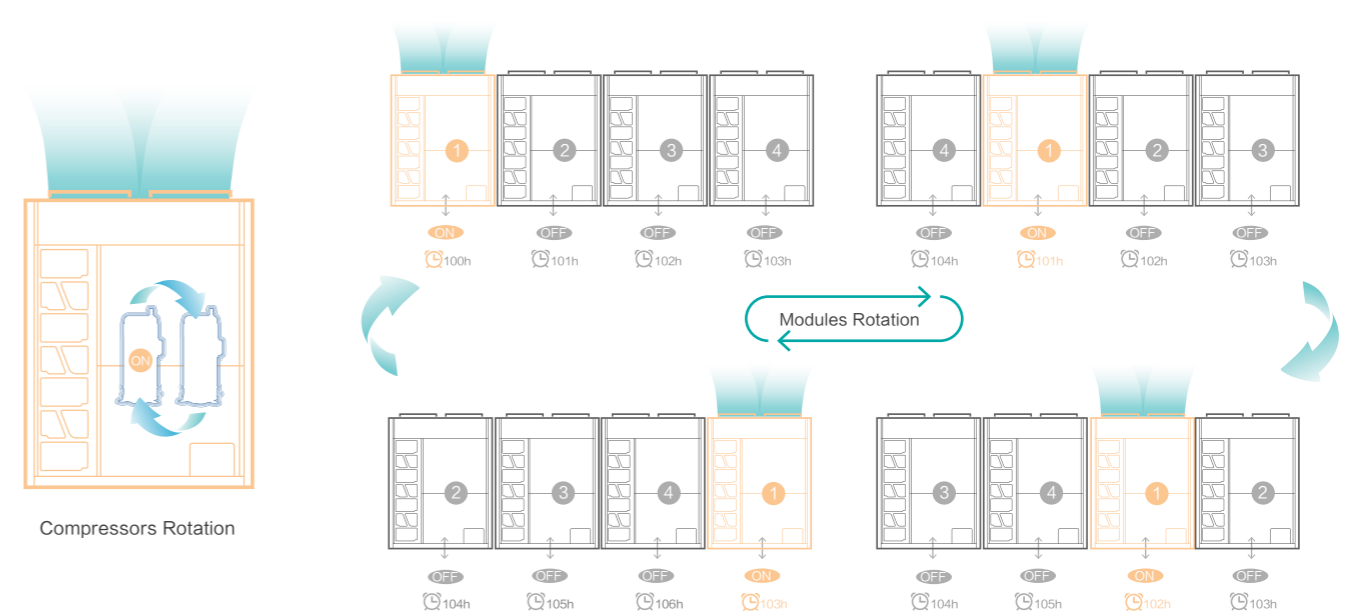



## Triple Backup Operation

### Module Backup Operation

If one module in a combination system malfunctions, the other ones can still keep working to ensure an emergency operation until service and repair.



### Compressor Backup Operation

In the single module system equipped with two compressors, if one compressor malfunctions, the other one can provide emergency operation. In the combined modules, if the compressor in one module goes wrong, the other modules can provide emergency operation. Thus a stable and continuous operation can be ensured thanks to the backup of compressors.

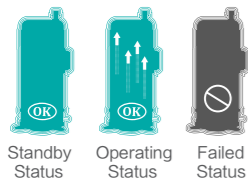

Compressor Backup



Outdoor Unit Backup

### Fan Backup Operation

For the module equipped with two fans, if one fan breaks down, the other one won't be influenced, the module can still keep working.



Single Module System



Combined Modules System

## Enhanced Anti-corrosion Solution (Optional)

The complete corrosion-proof solution of S mavo series cooling only unit is your optimal choice when it comes to seaside and chemical factory applications, providing ultimate comfort without sacrificing life span and lowers maintenance cost simultaneously. Besides the heat exchanger, components from top to toe are treated with effective treatments, and the Hisense anti-corrosion solution has already got the UL certification.

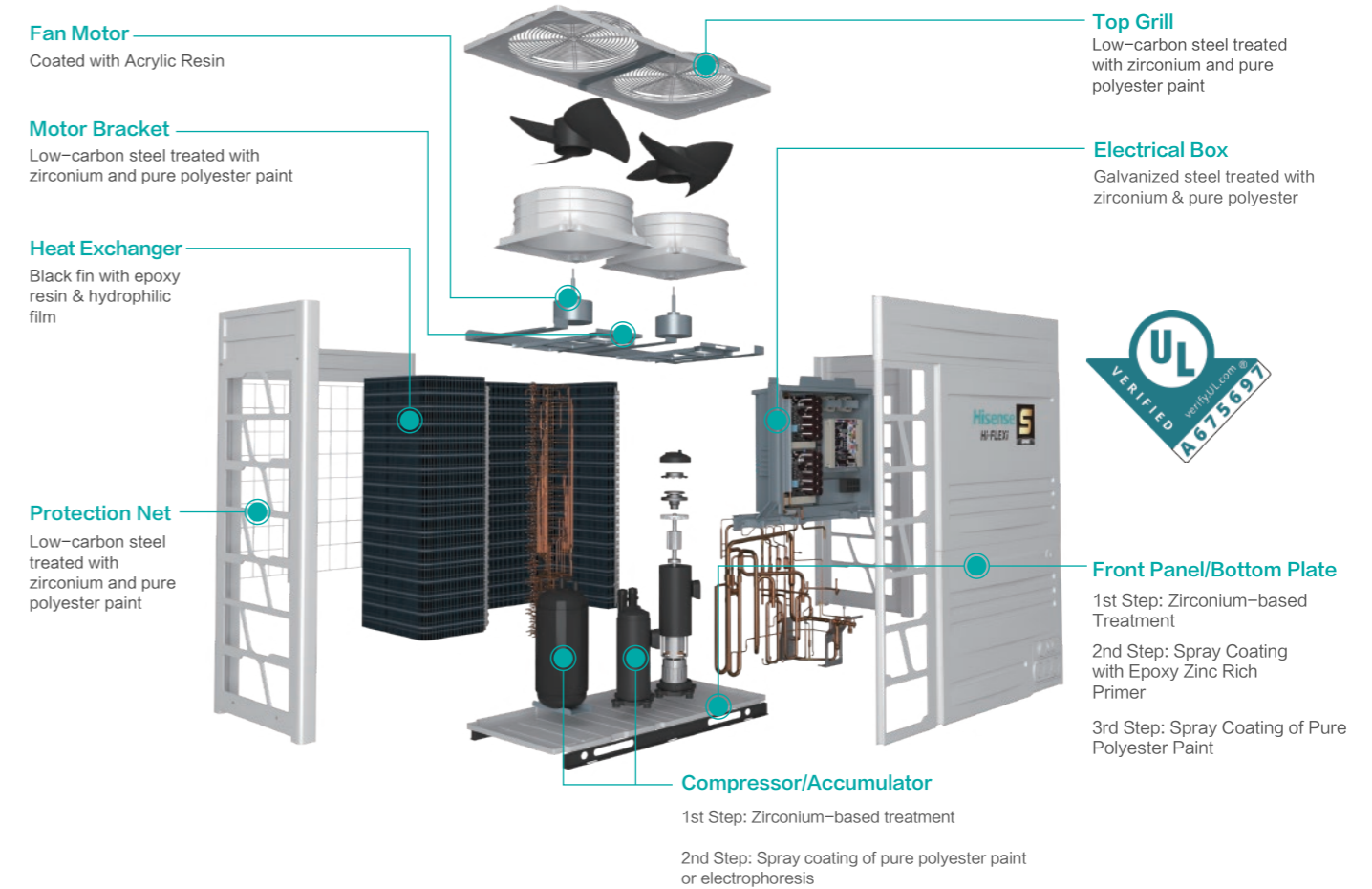

## Wider Operation Temperature

Extended operation range creates wider application potential. Hi-FLEXI S mavo series cooling only unit can working stably from 10°C to 52°C, which adapts to many extreme conditions.

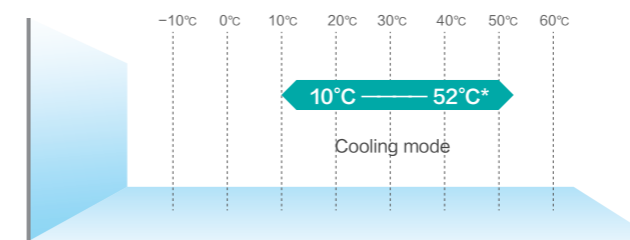

Note: When the ambient temperature is between 48°C to 52°C, the system may be in intermittent operation state. Please consult with local engineers.

### Automatic Restart

Hisense indoor units are capable to restart automatically to the previous state whenever the power supply is shut off suddenly and restores immediately. When there is long power shortage, the default setting is to keep all the indoor units off when the power restores. Also there are two other settings for users' choice, recovering to the state before power failure or restarting all the indoor units.

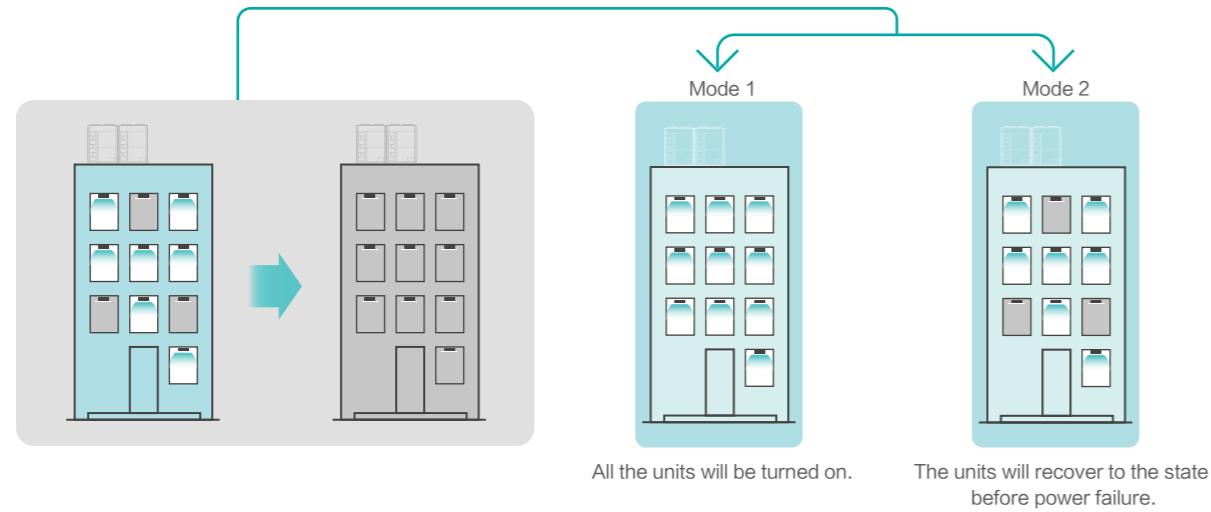

### Insect Protection of Electrical Box

The electric box is well designed. It can effectively prevent small insects from entering while ensuring good heat dissipation. The gap of the heat emission hole is less than 3mm.

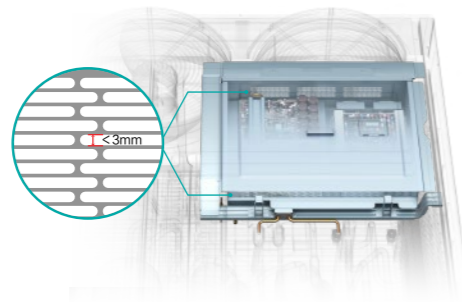

### Voltage Protector Reserved (Optional)

Too low or too high voltage can easily cause damage to electronic components. Hi-FLEXi S mavo series cooling only unit has reserved the space for assembling the voltage protector, which can be an effective solution to protect outdoor units from any voltage spikes. The power supply of outdoor unit will be automatically cut off when there is abnormal voltage, and will be restored when power supply returns to normal after 30s. Meanwhile, it's helpful for checking the phase sequence error or phase loss according to the indicator lights, convenient for commission and maintenance.

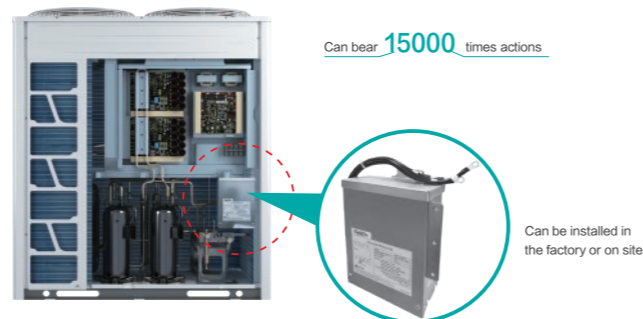

### Independent Maintenance of Indoor Units

To maintain the whole system's continuous operation even when there is a breakdown occur within a system, HI-FLEXi S mavo series cooling only system is capable to isolate the malfunction unit from the others while conducting restoration and maintaining continuous operation of other units simultaneously.

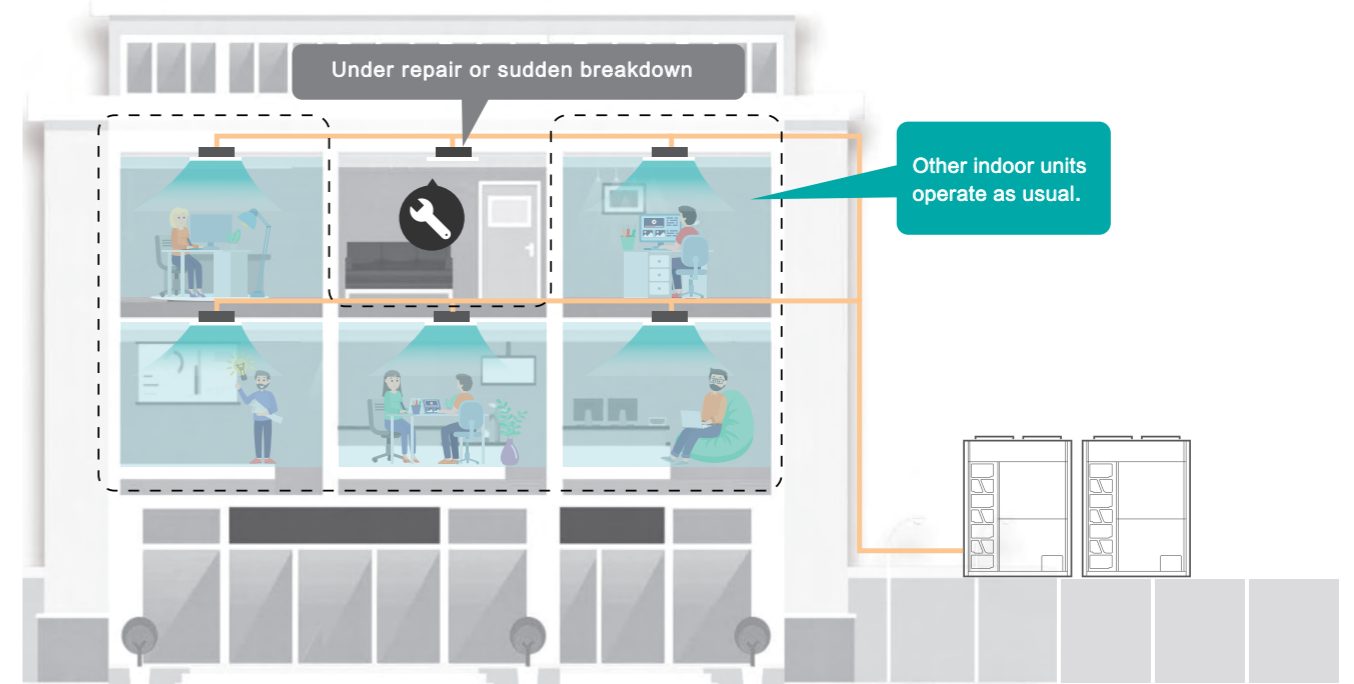

\*Preliminary setting is unnecessary

### Condensate Water Leakage Protection

Indoor units have built-in water-leakage float switches. Alarming warning will be displayed on the controller when condensate reaches a certain level. Save your ceiling and carpet from being soaked in time when drain pipe is clogged or drain pump breakdown.

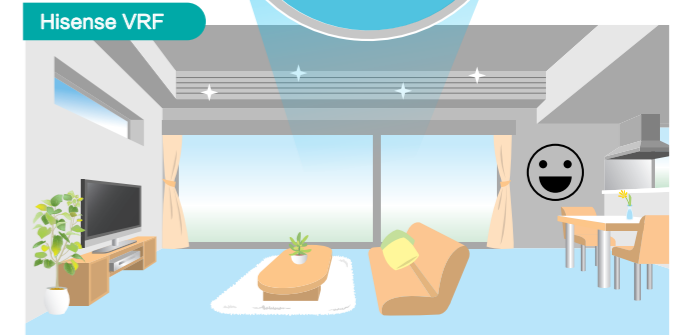
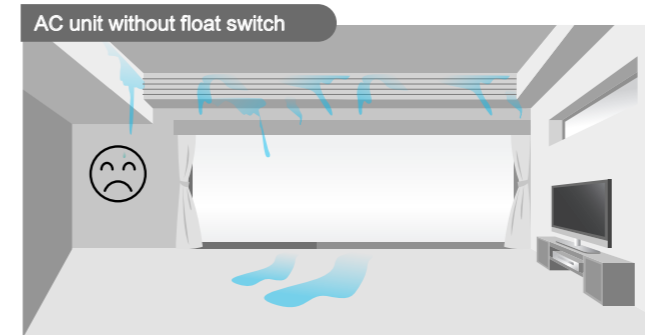
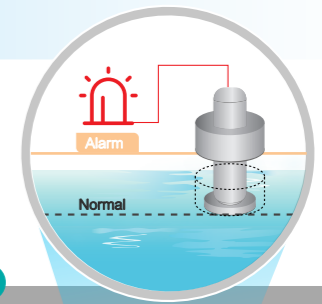

# High Efficiency

COOLING ONLY



- High-efficiency Compressor
- Auto Refrigerant Temperature Control (ART)
- New Heat Exchanger Design
- High-efficiency Subcooling Technology
- Stepless Fan-speed Control

COOLING ONLY

## High-efficiency Compressor

Hi-FLEXI S mavo series cooling only unit adopts a new generation of scroll compressor, and it has an excellent mechanism called as FCM (Frame Compliant Mechanism) which will optimally increase the performance of the whole compressor, especially for operation under low load.

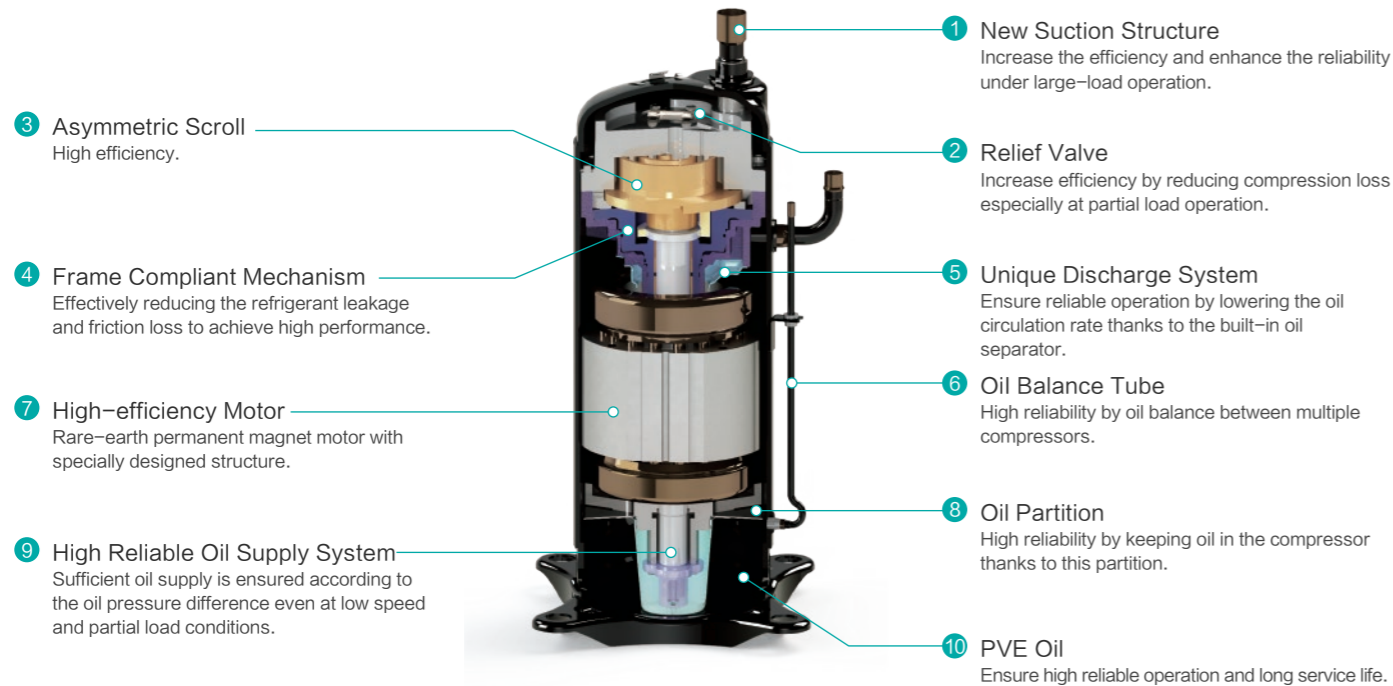

## Two-stage Back Pressure Control

There are two-stage back pressure control mechanism inside the compressor. The back pressure could force the tightness between movable and static scrolls, reducing the refrigerant leakage during low-load operation and ensuring a stable and efficient low-load operation.

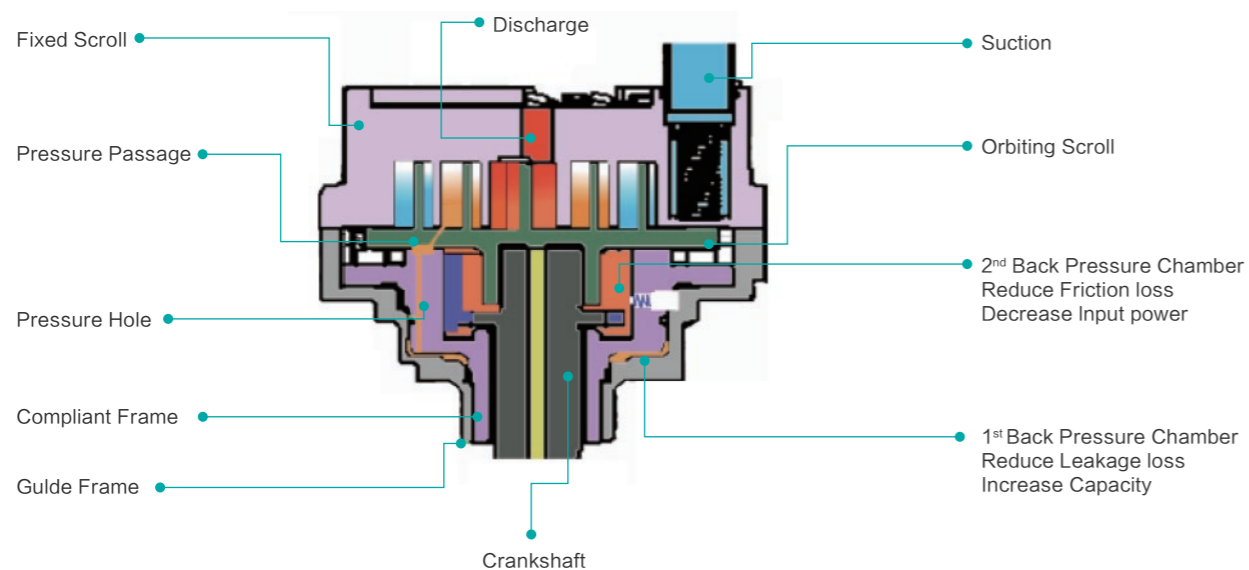

## Low Oil Circulation

Oil remaining in the piping system can cause performance drop. The new compressor has a special structure design called "oil cup" for reducing the percentage of oil circulation outside the compressors. The oil circulation ratio for the new compressor can be reduced by 50% and 10% during the start-up and stable working stage respectively, compared to conventional compressor.

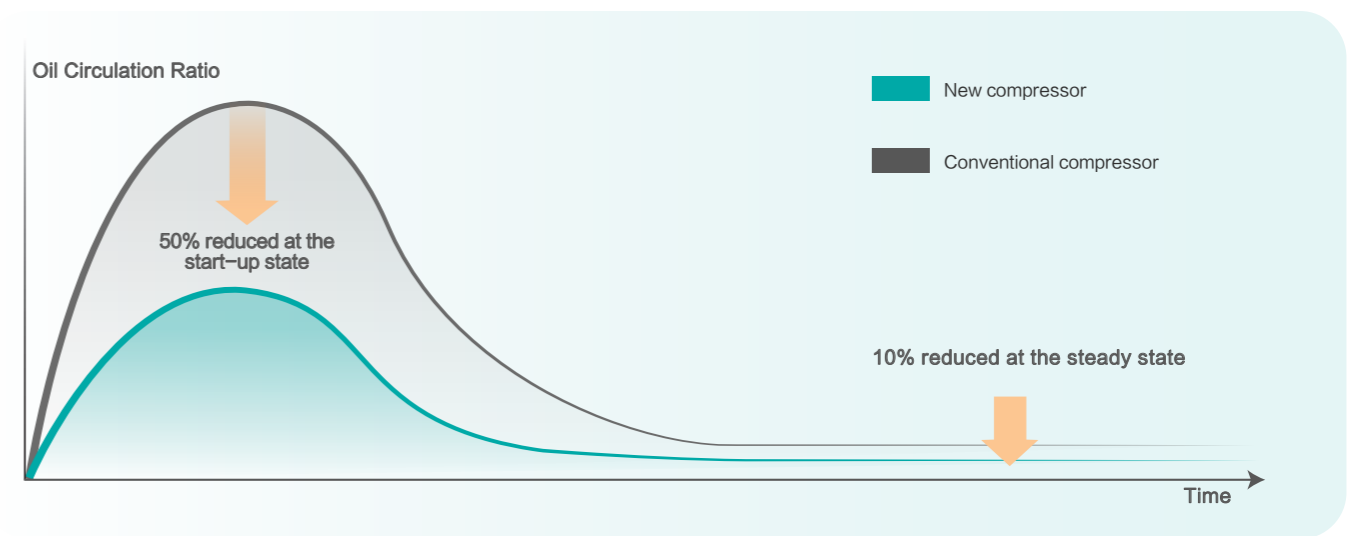

## Auto Refrigerant Temperature Control (ART)

Hisense VRF system featured with ART technology can meet the indoor loads more accurately at a higher efficiency. The system adjusts the evaporating temperature (Et) according to actual indoor loads automatically in a wide range. The Et is raised to minimize the difference with the condensing temperature when the air-conditioning load is low, thus further improving the energy efficiency.

### Features:

- 1) Energy efficiency is improved without sacrificing comfort.
- 2) ART is particularly efficient under low-load operation.
- 3) The initial evaporation temperature can be adjusted between 2-11°C, which is the widest in the market.
- 4) Realize rapid cooling with lower evaporating temperature.
- 5) Avoiding cold draft with higher evaporating temperature.

$$Et = Et_0 + K$$

Et: Evaporation temperature

Et<sub>0</sub>: The initial evaporation temperature

ΔT: The temperature difference between air inlet and the setting temperature

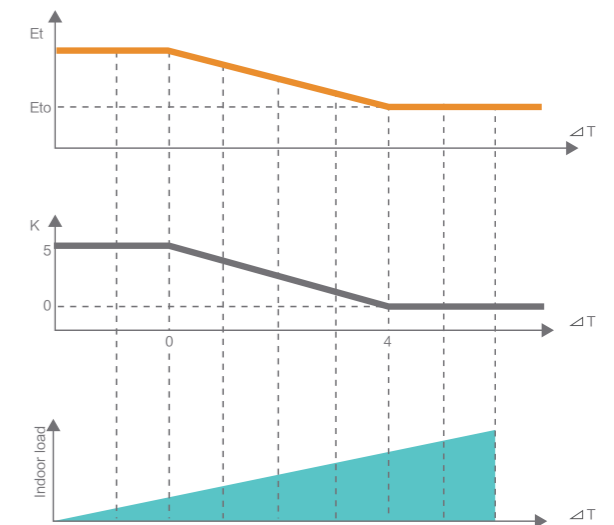

## New Heat Exchanger Design

### Optimized Refrigerant Circuit

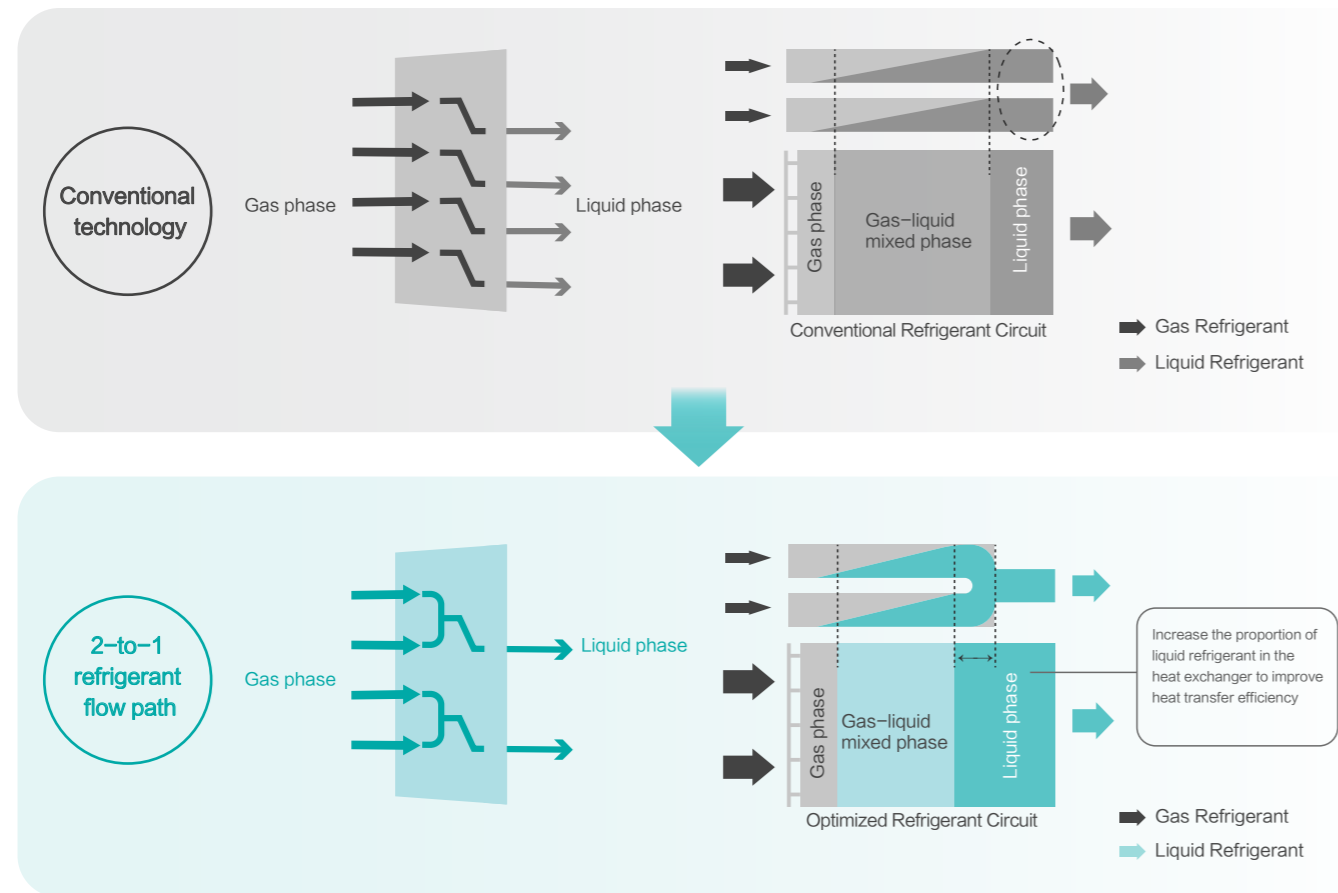

### New Advanced Corrugated Fin Design

The new advanced corrugated fins are applied in the heat exchanger. With this new design, larger amount of fins can be allocated into the heat exchanger, increasing 21% heat exchange surface area. Also the air flow resistance is largely reduced by 20%, thus the heat exchange efficiency is improved greatly.

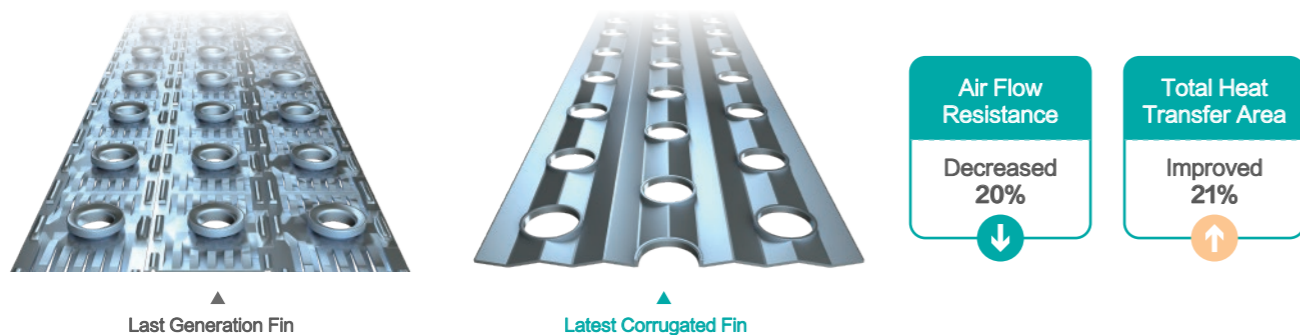

## High-efficiency Subcooling Technology

Hi-FLEXi S mavo series cooling only unit adopts new high-efficiency plate heat exchanger while heat exchange capacity increased by 35% and the volume of the plate heat exchanger is decreased by 65.5% under the same heat exchange capacity, compared with the conventional one. Together with the optimized heat exchanger, the total subcooling of the system can be up to 27°C.

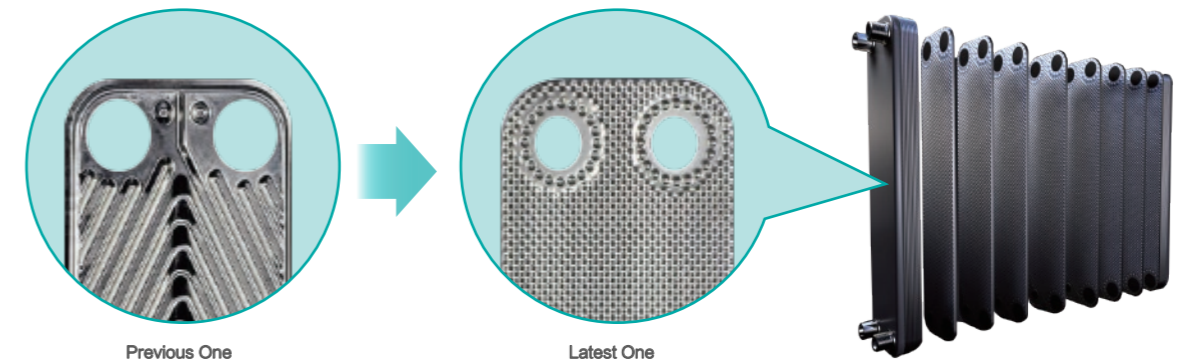

## Stepless Fan-speed Control

The DC inverter motor equipped in the outdoor unit can realize stepless fan-speed adjustment to ensure system efficiency and stability. Hi-FLEXi S mavo series cooling only unit optimizes the motor support structure, which can increase 10% air volume at the same speed and reduce the noise greatly.

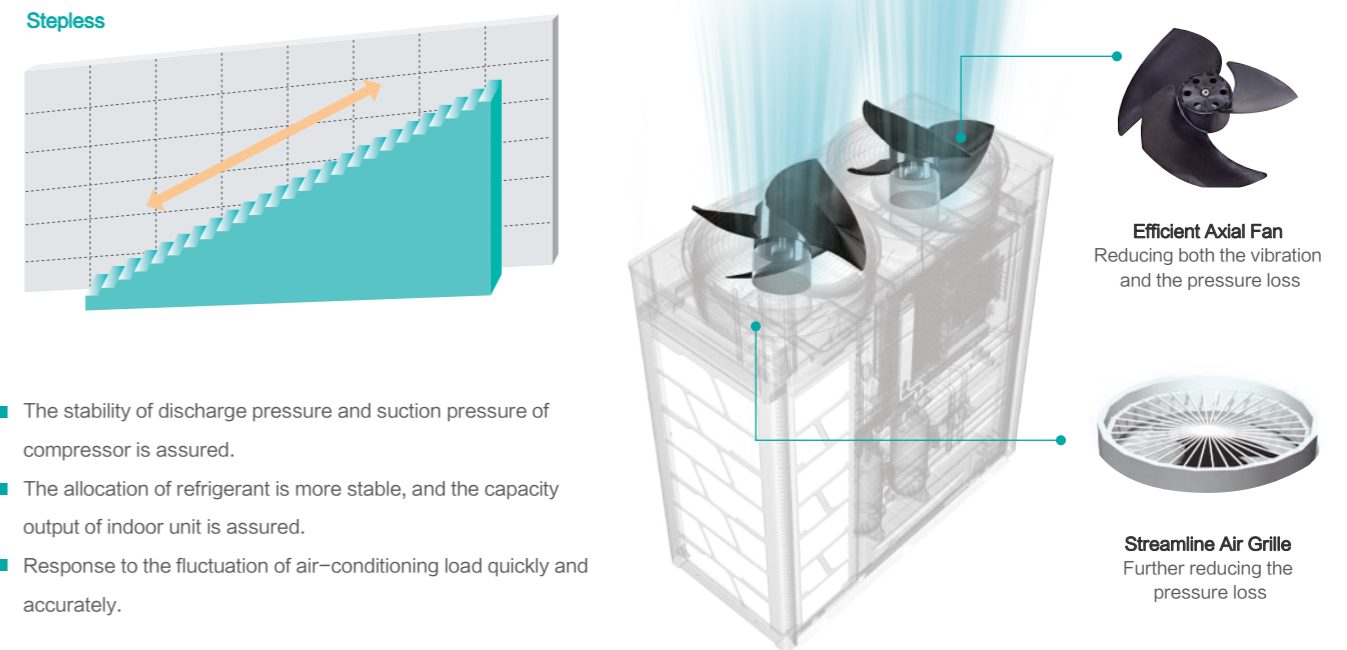

# Comfort

COOLING ONLY



- VIP Mode
- Precise Temperature Control
- Top Class Low-noise Control
- Clean and Fresh Air
- Smart Air Flow

COOLING ONLY

## VIP Mode

Hisense VRF offers VIP mode to give priority to the specific room, keeping them comfortable and satisfied as fast as possible and 5 indoor units can be set as VIP mode at the same time. Such function is exclusively practical for hotel application, where air conditioners in the presidential suite are often set to VIP mode.



## Precise Temperature Control

There are multiple temperature sensors equipped in the system, which will be very helpful to judge the indoor load more accurately. Also the 2000-step EEV is specially adopted to ensure precise refrigerant flow adjustment according to the actual load of indoor units, achieving a more comfortable indoor environment with small temperature fluctuation.

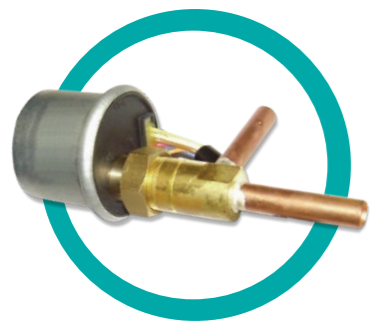

2000-step EEV

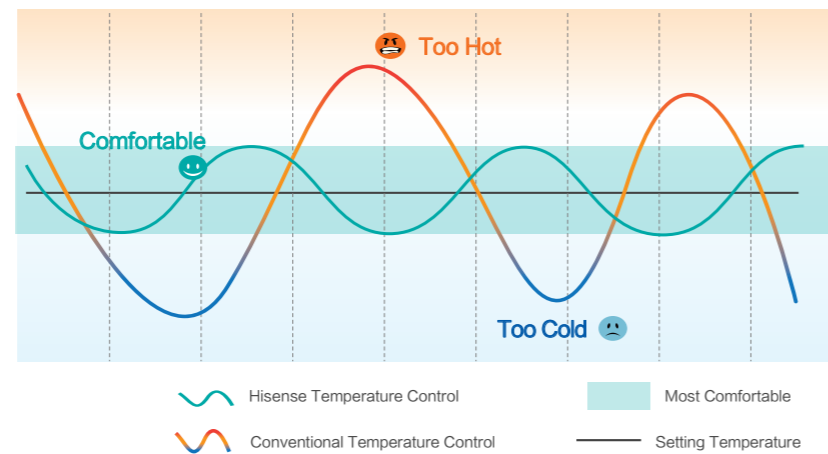

## Top Class Low-noise Control

### Low Noise for Indoor Unit

Noise is often a pain in the neck. Hisense indoor units can provide more quiet environment to users, with sound pressure level as low as 21dB(A), which perfectly blends into library, auditorium and hospital room where require sound level lower than 25dB(A).

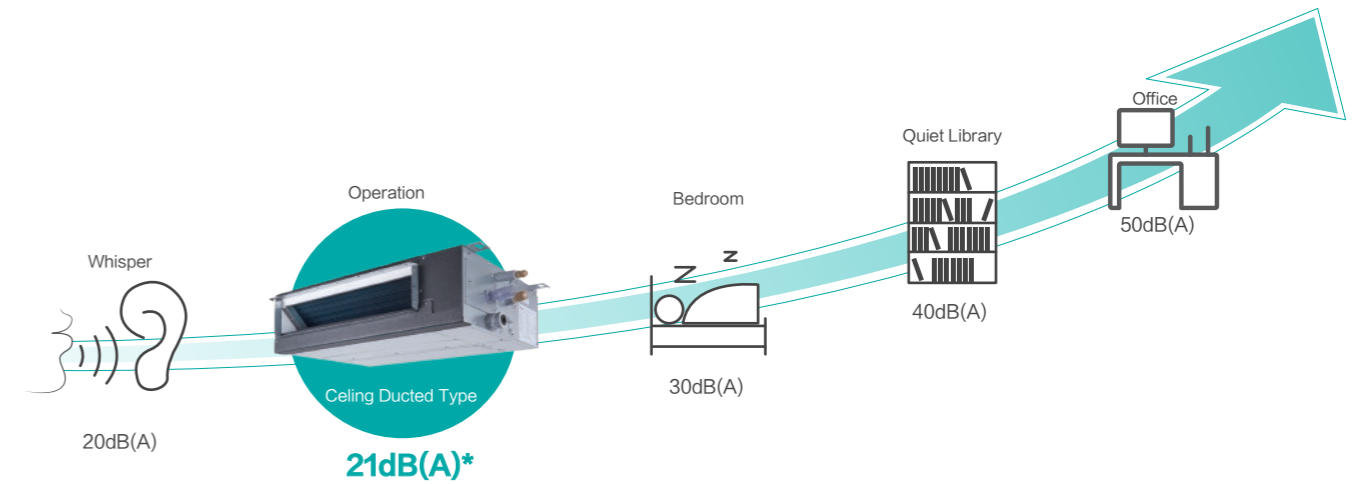

\*The DC ceiling ducted type (AVE-05HJFDL) can achieve the 21dB(A) under the standard test condition.

### Outdoor Unit Night Quiet Mode

In general, people are more sensitive to noise at night. To provide more quiet environment, night quiet mode function of outdoor units can be adopted to reduce sound pressure level by up to 19dB(A).

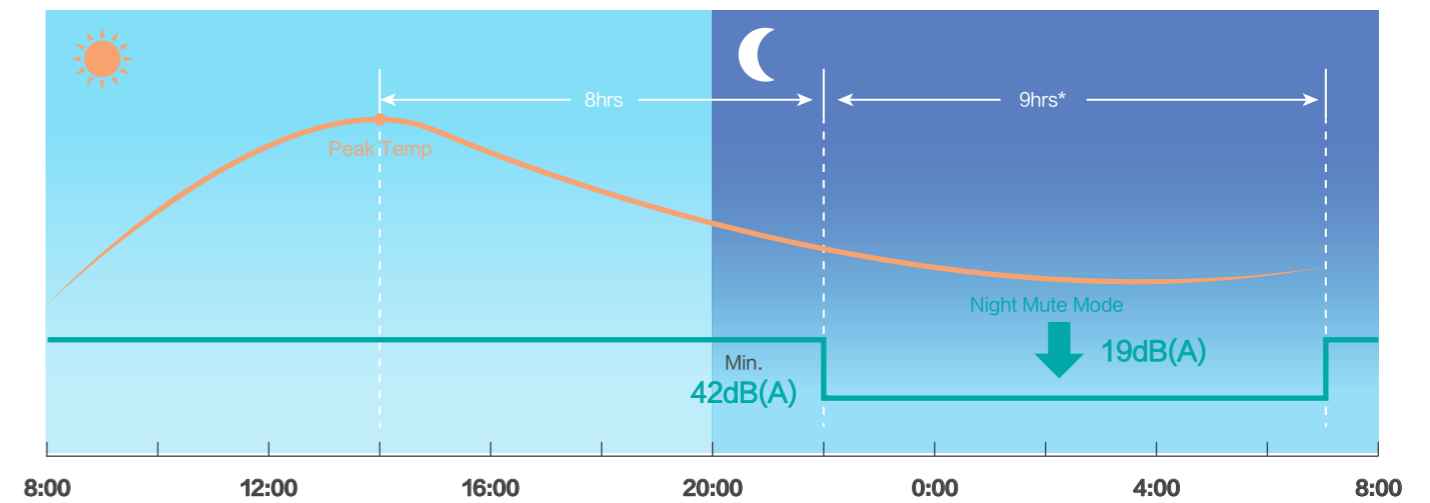

\*The night mute mode can last for 8hrs, 9hrs or 10hrs according to the setting. Take AVWT-96CKFSE as an example.

— Temp Change Curve      — Noise Change Curve

## Clean and Fresh Air

### AirPure

Hisense VRF indoor unit equipped with AirPure kit can release lots of negative ions, about 20 million pcs/cc. These negative ions are carried throughout the room with air-conditioned air flow whereby obtaining air conditioning and air purification simultaneously. With the AirPure kit, the indoor unit has got the Tick Mark certification for air-conditioning sterilization products.



\*Take AVE-09HCFRL as the test sample.

Note: 4-way Cassette, Mini 4-way Cassette, Console and Ceiling Ducted can be equipped with the AirPure kit.

### Silver Ionizer (Optional)

For Hisense VRF, silver ionizers are optionally infused in indoor units to disinfect drain pans where condensate water constantly stagnant.

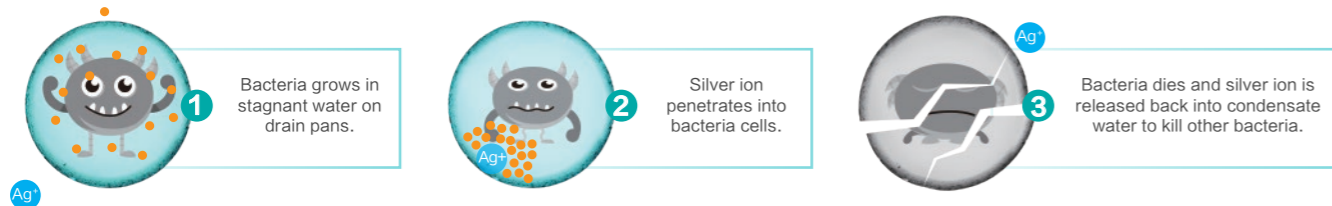

Note: 4-way Cassette and Mini 4-way Cassette are available for the function.

### Fresh Air Intake

Hisense VRF indoor units are infused with a fresh air duct opening for 10% free fresh air introductory directly from outdoor air, reducing the need of fresh air systems for medium to small spaces. These indoor units include 4-way cassette, mini 4-way cassette, 2-way cassette, 1-way cassette, AC/DC low height ceiling ducted, low/high static pressure ceiling ducted and console.

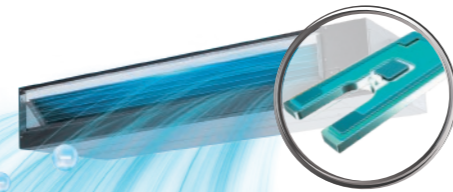
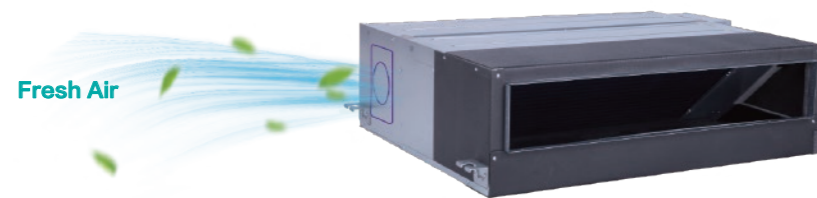

AirPure

- Anti-Bacteria and Anti-Virus
- Formaldehyde Removal
- Anti-mold
- Odor Removal
- PM2.5 Purification
- Anti-allergen

### Humidity Sensor (Optional)

To keep up with the indoor quality requirements, Hisense VRF offers auto dehumidification function and it can be achieved by choosing a humidity sensor, and the control range is from 35% to 90%.

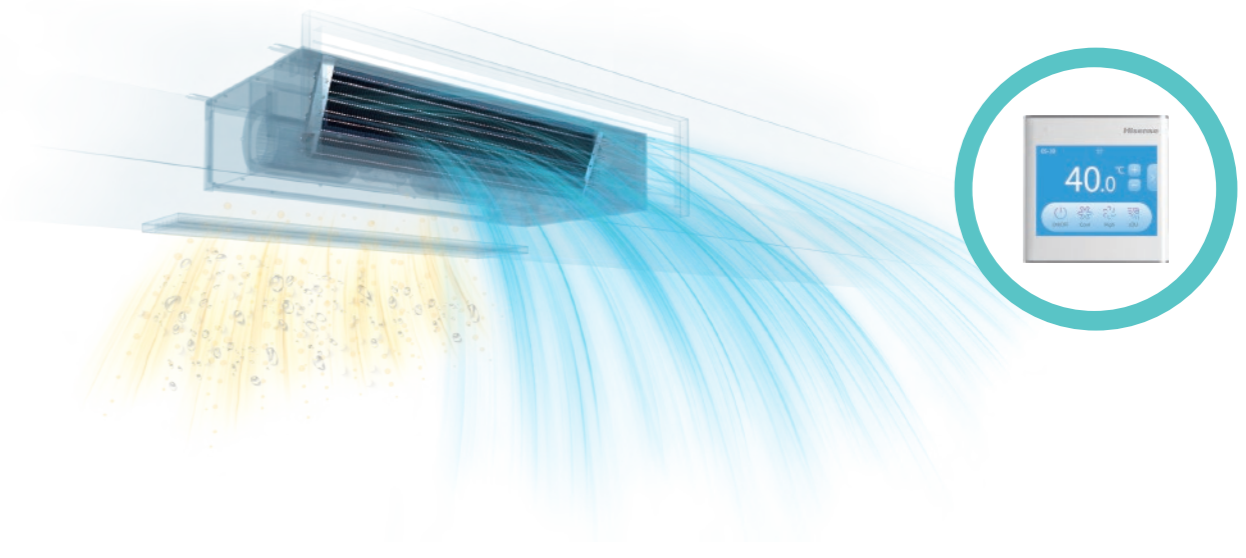

## Smart Air Flow

### 3D Air-flow Panel (Optional)

The panel is an optional accessory for low height ceiling ducted indoor unit. By using Hisense's luxurious looking, smooth, easy to clean 3D air-flow panel, it saves the hassle in buying normal louvers. It has LED temperature and humidity level display which is perfect for various applications. It also has selectable wind setting from normal, 3D and super long distance modes, cool or warm air flows out from the panel according to the wide horizontal and vertical louvers with 7 options.

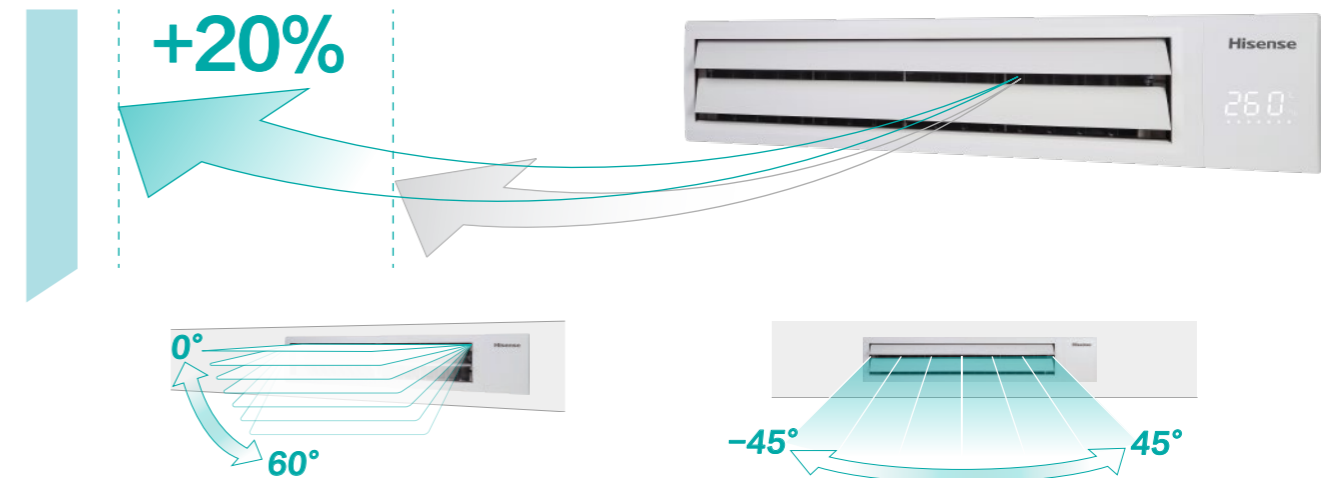



**Micro-holes and Breeze Mode**

Different regions and country have different preference and personal viewpoint of comfort. Some may prefer cool chilly air from AC unit to cool down the room without wind gushes directly towards their faces or bodies. Hisense VRF's 4-way Cassettes are now designed with micro-holes on every corners on the panels making full use of the whole panel to cool down spaces evenly.

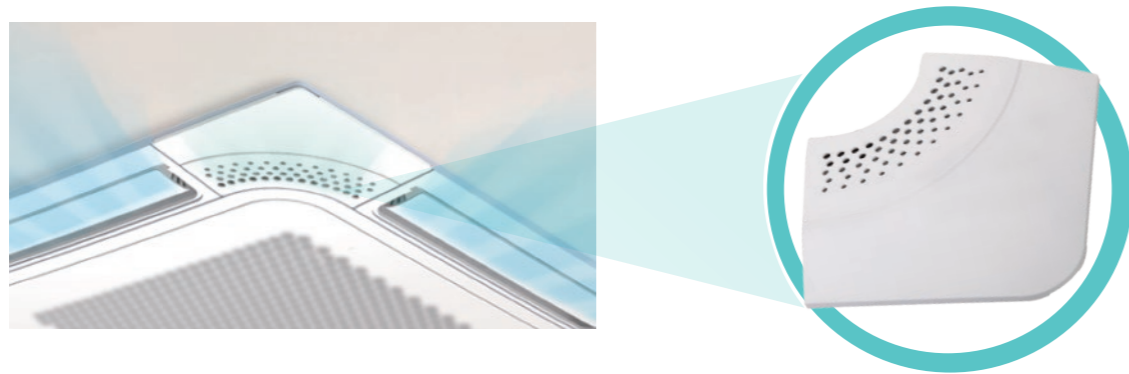

**Individual Louver Control**

4-way cassette's louvers are now capable of individual control to freely choose how you want your AC unit supplies air according to different needs, applications and installation layout. Each louvers have 7 angle settings with angle range from 28° to 52°.

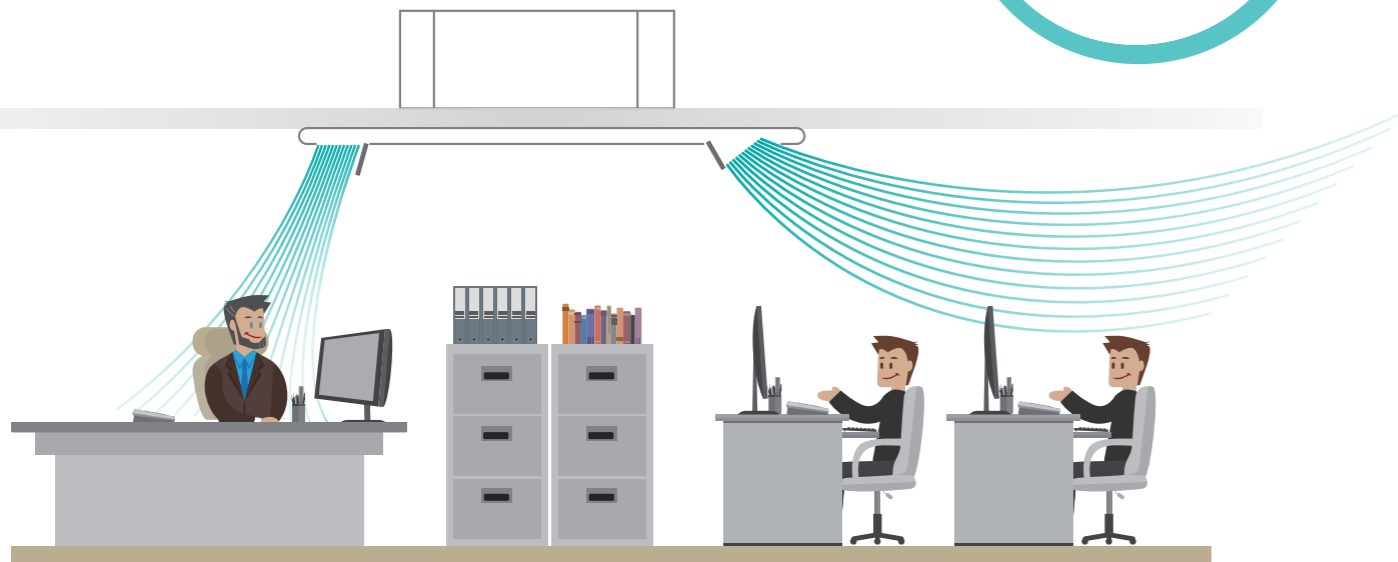
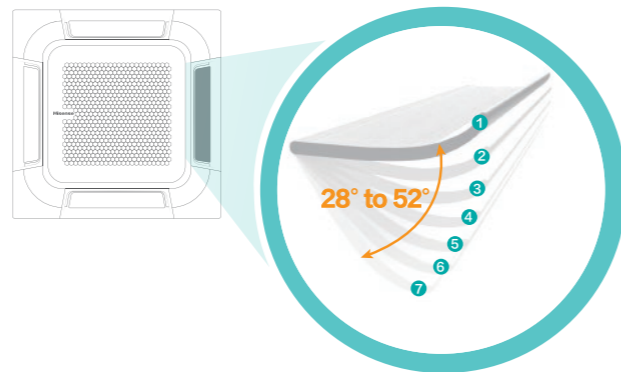

**Hi-Motion (Optional)**

With fashionable appearance, Hi-Motion can provide not only a comfortable environment but also energy-efficient operation.

- 1) Automatically stops the unit when no one is in the room in order to realize energy saving.
- 2) Adjusting the setting temperature and air flow according to the actual human activity.

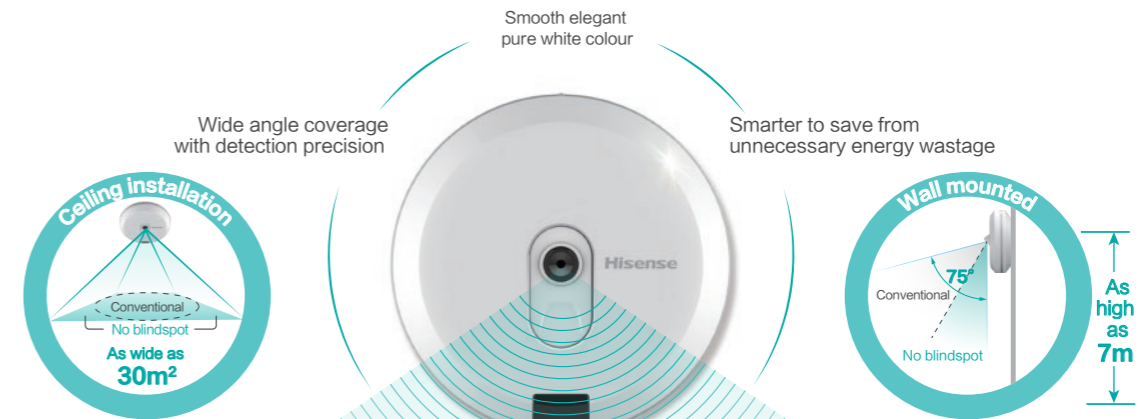

**Motion Sensor (Optional)**

Motion Sensor can provide a more comfortable environment, and achieve efficient and energy-saving operation of the unit at the same time.

- 1) With the sensor, indoor unit can ON or OFF automatically when people enter or leave the room.
- 2) The people location can be detected by the sensor automatically, and the air flow direction can be set to blow directly or to avoid blowing at people as they like.
- 3) The setting temperature can be changed automatically by detecting the number of people changing.

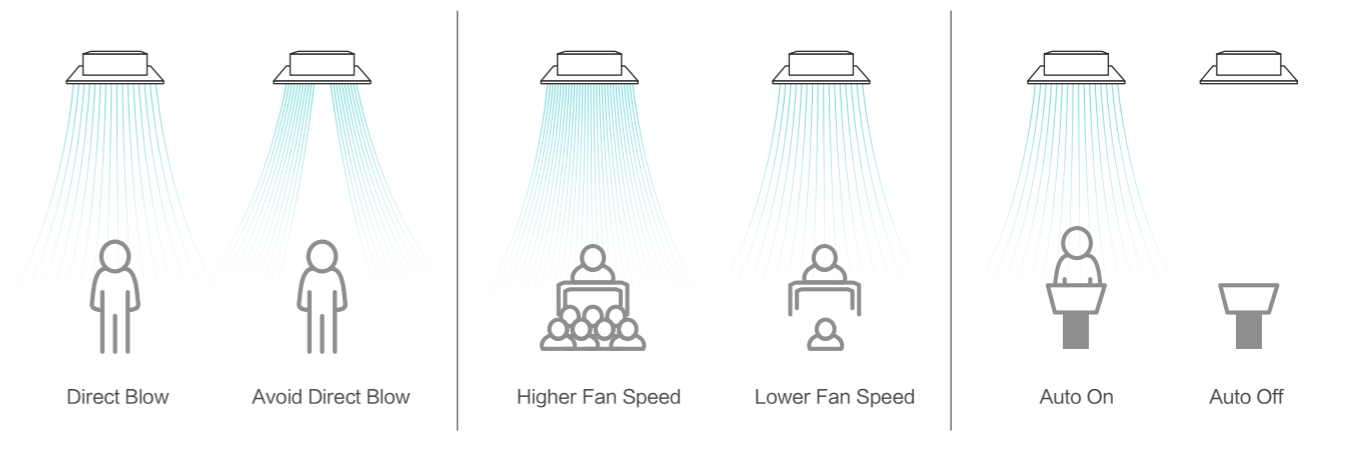

# Flexibility

COOLING ONLY

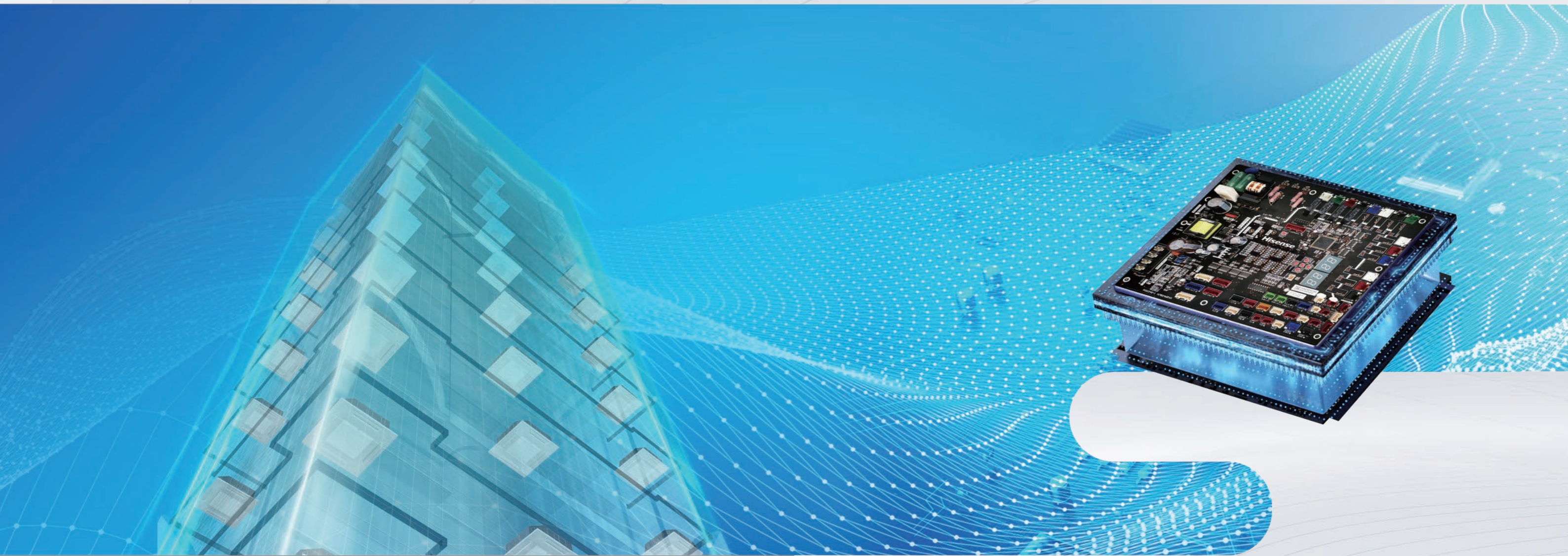

- Flexible System Design
- One-touch Test Run
- Automatically Addressing
- Intelligent System Diagnosis
- Dry Contact Interface
- Safe and Convenient System Management
- One-touch Refrigerant Recycle
- Flexible Emergency Operations
- Extra-high External Static Pressure Design
- Separated Mechanical and Electrical Compartment

COOLING ONLY

## Flexible System Design

### Long Piping Length

With extra long pipe, the height difference between the indoor unit and outdoor unit is up to 90 meters\*, which makes installation more flexible.

Maximum height difference of indoor units: 30m\*

Maximum length from the first branch pipe to the farthest indoor unit: 90m

Largest pipe length between outdoor units: 10m

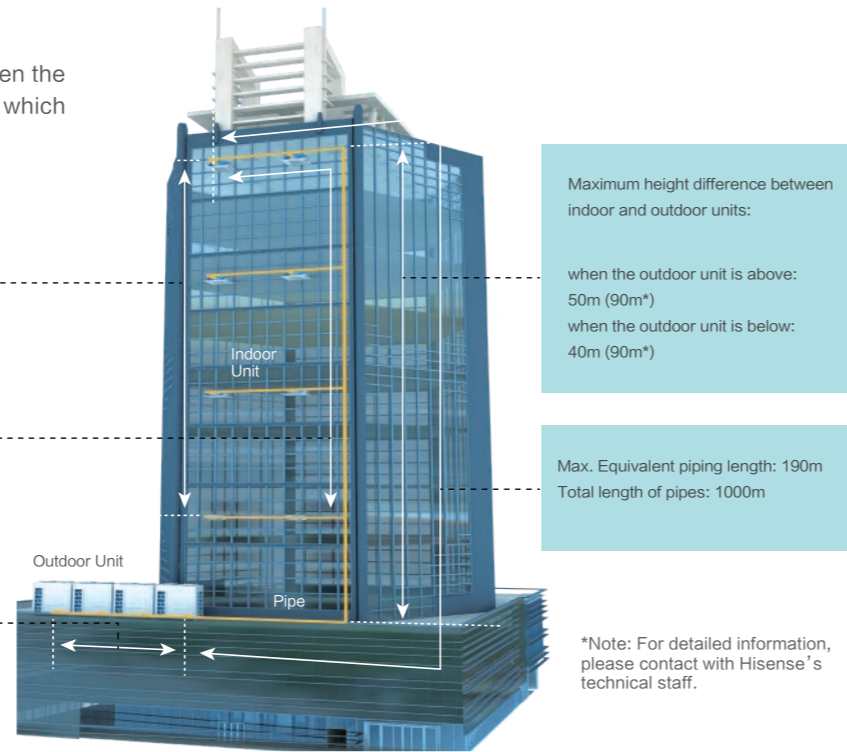

\*Note: For detailed information, please contact with Hisense's technical staff.

### Max. 200% of Connection Ratio

The max. connection ratio between indoor units and outdoor units in the single module system can reach 200%, which can improve the flexibility of design largely and reduce the cost of projects whose air condition systems always work under partial load considerably. For double modules, triple modules and four module combined units, the max. connection ratios are 180%, 160%, 150% respectively.



Connection Ratio Condition	
Single Module Unit	200%
Double Modules Combined Unit	180%
Triple Modules Combined Unit	160%
Four Moudule Combined Unit	150%

## Dry Contact Interface

External input & output ports are reserved in indoor units and outdoor units for a wider choice of applications to control the air conditioning system. The key-card control, window contact control and any other third-party sensors or devices control can be available through setting in the indoor units or outdoor units.

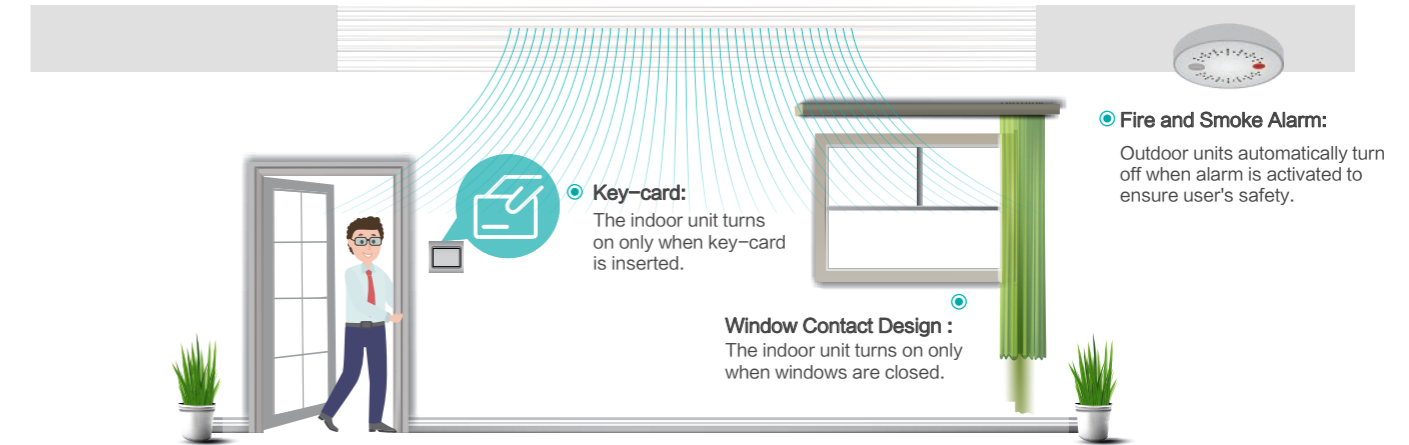

## Extra-high External Static Pressure Design

External static pressure is essential to determine the air discharge and duct connection length. The max. ESP of S mavo series cooling only unit is 110Pa. Allow longer ducting connection for better air discharge when are installed in the equipment platform that is not easy to exhaust.

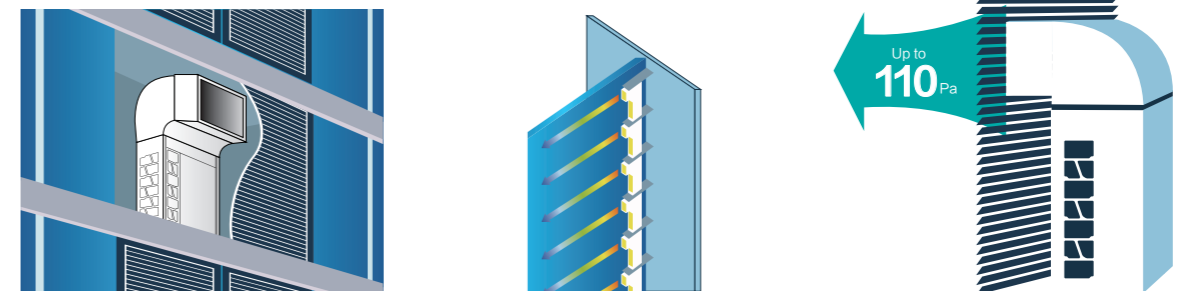

Note: The initial setting is 80Pa. Can be set to 110Pa from the PCB on site.

## One-touch Test Run

Test run is one of the essential parts in testing & commissioning to make sure the VRF system in a building works steadily and safely before handing over or soft openings. To make test run as simple as possible, Hi-FLEXI S mavo series cooling only unit is capable to conduct test runs with just a button away wherever installers are, one-touch test run functions are applicable in both outdoor units and controllers.

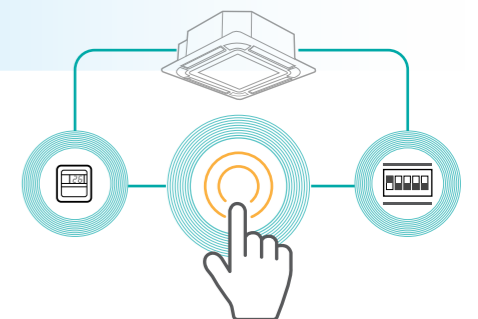

### Safe and Convenient System Management

The new outdoor units are equipped with a service window on top of the electrical box protection panel, providing easy access to parameters check. No need to disassemble the panel, decreasing the risk of electric shock.

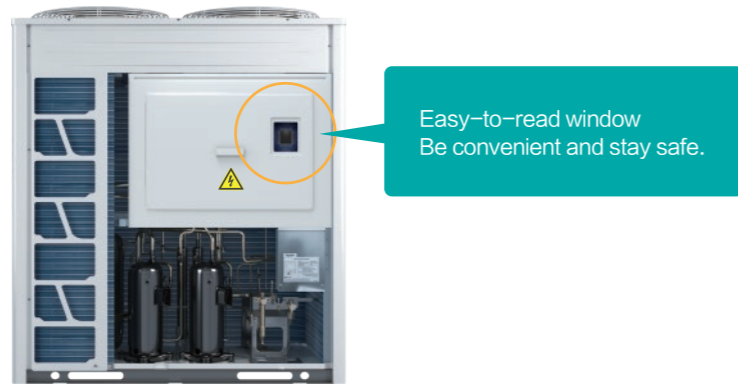

### Separated Mechanical and Electrical Compartment

Hi-FLEXi S mavo series cooling only unit has separated electrical and mechanical compartments and they are covered with independent panels. Service Engineers are free to take the panels apart to check and maintain every details conveniently. All designs provide the convenience for installation and maintenance.



### Automatically Addressing

As the system gets larger, the number of indoor units will increase rapidly, and the setting of address for IDUs will become more and more complicated. Hi-FLEXi S mavo series cooling only unit provides an automatic addressing function. The system can automatically address indoor units. It is very simple and convenient for installation and commissioning.

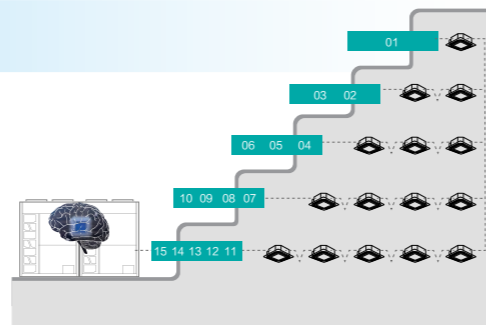

### One-touch Refrigerant Recycle

Hi-FLEXi S mavo series cooling only unit has one-touch refrigerant recycle function. Just with a press of the button on the PCB, the refrigerant can be recycled directly, it is very helpful and convenient when the indoor units or the compressor are under repair.

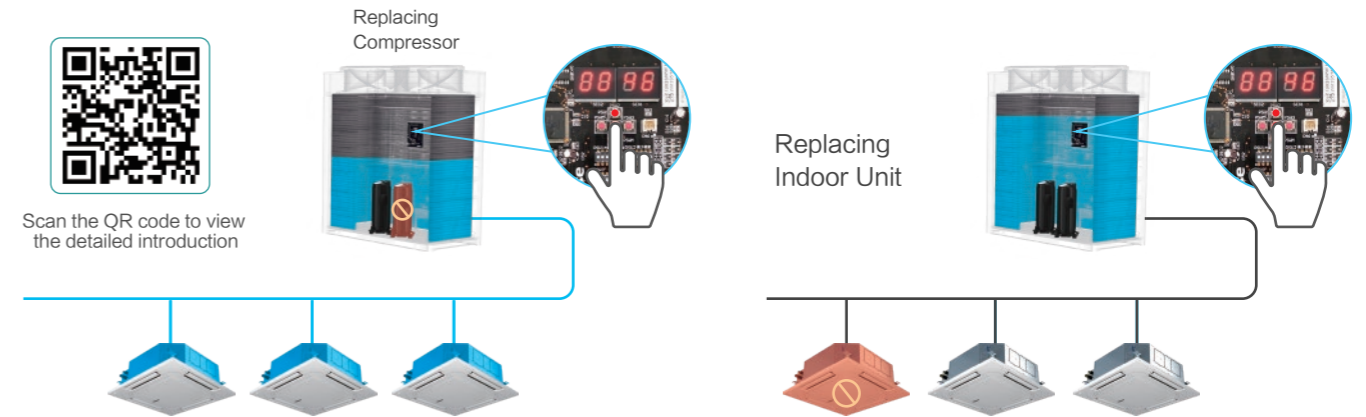

### Intelligent System Diagnosis

Exclusive Hi-Checker is a super service tool for system diagnosis, which can provides easy access to service parameters. Detail operation status and recent error history can be checked and analyzed by using Hi-Checker.



### Flexible Emergency Operations

Under hot ambient temperature, it will cause lots of trouble once the air conditioning system shuts down. Hi-FLEXi S mavo series cooling only unit can provide six kinds of emergency operations, which can be easily set through controllers, PCB or inverter driven plate. When the compressor, fan motor, driven plate of fan motor, driven plate of compressor, temperature sensor of compressor or temperature sensor of compressor driven plate malfunctions, the air conditioning system can keep continuous working by changing settings.

# Outdoor Unit

COOLING ONLY



- AVWT-76CKFSE
- AVWT-96CKFSE
- AVWT-114CKFSE
- AVWT-136CKFSE
- AVWT-154CKFSE
- AVWT-170CKFSE
- AVWT-190CKFSE
- AVWT-212CKFSE
- AVWT-232CKFSE
- AVWT-250CKFSE
- AVWT-272CKFSE

COOLING ONLY

### Standard Combination

Capacity	Model	14HP	16HP	18HP	20HP	22HP	24HP	26HP	28HP
30HP	AVWT-290CKFSE	•	•						
32HP	AVWT-308CKFSE		••						
34HP	AVWT-324CKFSE		•	•					
36HP	AVWT-340CKFSE			••					
38HP	AVWT-360CKFSE			•	•				
40HP	AVWT-382CKFSE			•		•			
42HP	AVWT-402CKFSE			•			•		
44HP	AVWT-422CKFSE				•		•		
46HP	AVWT-444CKFSE					•	•		
48HP	AVWT-464CKFSE						••		
50HP	AVWT-482CKFSE						•	•	
52HP	AVWT-504CKFSE						•		•
54HP	AVWT-522CKFSE							•	•
56HP	AVWT-544CKFSE								••
58HP	AVWT-552CKFSE			••		•			
60HP	AVWT-572CKFSE			••			•		
62HP	AVWT-592CKFSE			•	•		•		
64HP	AVWT-614CKFSE			•		•	•		
66HP	AVWT-634CKFSE			•			••		
68HP	AVWT-654CKFSE				•		••		
70HP	AVWT-676CKFSE					•	••		
72HP	AVWT-696CKFSE						•••		
74HP	AVWT-714CKFSE						••	•	
76HP	AVWT-732CKFSE						•	••	
78HP	AVWT-754CKFSE						•	•	•
80HP	AVWT-776CKFSE						•		••
82HP	AVWT-794CKFSE							•	••
84HP	AVWT-816CKFSE								•••
86HP	AVWT-824CKFSE				••	•	•		
88HP	AVWT-844CKFSE				••		••		
90HP	AVWT-866CKFSE				•	•	••		
92HP	AVWT-886CKFSE				•		•••		
94HP	AVWT-908CKFSE					•	•••		
96HP	AVWT-928CKFSE						••••		
98HP	AVWT-946CKFSE						•••	•	
100HP	AVWT-968CKFSE						•••		•
102HP	AVWT-986CKFSE						••	•	•
104HP	AVWT-1008CKFSE						••		••
106HP	AVWT-1026CKFSE						•	•	••
108HP	AVWT-1048CKFSE						•		•••
110HP	AVWT-1066CKFSE							•	•••
112HP	AVWT-1088CKFSE								••••

### High-efficiency Combination

Capacity	Model	8HP	10HP	12HP	14HP
16HP	AVWT-152CKFSH	••			
18HP	AVWT-172CKFSH	•	•		
20HP	AVWT-192CKFSH		••		
22HP	AVWT-210CKFSH		•	•	
24HP	AVWT-228CKFSH			••	
26HP	AVWT-250CKFSH			•	•
28HP	AVWT-268CKFSH	•	••		
30HP	AVWT-288CKFSH		•••		
32HP	AVWT-306CKFSH		••	•	
34HP	AVWT-324CKFSH		•	••	
36HP	AVWT-342CKFSH			•••	
38HP	AVWT-364CKFSH			••	•
40HP	AVWT-386CKFSH			•	••
42HP	AVWT-402CKFSH		•••	•	
44HP	AVWT-420CKFSH		••	••	
46HP	AVWT-438CKFSH		•	•••	
48HP	AVWT-456CKFSH			••••	
50HP	AVWT-478CKFSH			•••	•



## Standard Combination

### Outdoor Unit Specifications



Capacity			8HP	10HP	12HP	14HP	16HP	18HP		
Model			AVWT-76CKFSE	AVWT-96CKFSE	AVWT-114CKFSE	AVWT-136CKFSE	AVWT-154CKFSE	AVWT-170CKFSE		
Combination			AVWT-76CKFSE	AVWT-96CKFSE	AVWT-114CKFSE	AVWT-136CKFSE	AVWT-154CKFSE	AVWT-170CKFSE		
Power Supply			AC 3Φ, 380-415V/50/60Hz							
Cooling Operation	Capacity	kW	22.4	28.0	33.5	40.0	45.0	50.0		
		kBtu/h	76.4	95.5	114.3	136.5	153.5	170.6		
	Power Input	kW	4.81	6.54	7.92	10.18	12.16	13.97		
	EER	W/W	4.66	4.28	4.23	3.93	3.70	3.58		
Ventilation	Air Flow Rate	m³/min	183	183	183	200	200	200		
	Fan Quantity	pcs	1	1	1	2	2	2		
	Static Pressure	Pa	110	110	110	110	110	110		
Sound Pressure Level(Normal/Silent)			dB(A)		59/42	61/42	61/44	62/44	62/45	63/46
Compressor	Type	—	Scroll Compressor							
	Quantity	pcs	1	1	1	1	1	1		
Refrigerant	Type	—	R410A							
	Pre-charged Quantity	kg	6.4	6.4	7.8	10.0	10.0	12.3		
Weight	Net Weight	kg	212	213	218	260	262	285		
	Gross Weight	kg	240	241	246	291	293	315		
Cabinet Color			Ivory White							
Net Dimensions	Height	mm	1730	1730	1730	1730	1730	1730		
	Width	mm	950	950	950	1210	1210	1210		
	Depth	mm	750	750	750	750	750	750		
Packing Dimensions	Height	mm	1950	1950	1950	1950	1950	1950		
	Width	mm	1015	1015	1015	1275	1275	1275		
	Depth	mm	790	790	790	790	790	790		
Ref. Piping	Gas	mm	φ19.05	φ22.20	φ25.40	φ25.40	φ28.60	φ28.60		
		inch	3/4	7/8	1	1	1-1/8	1-1/8		
	Liquid	mm	φ9.53	φ9.53	φ12.70	φ12.70	φ12.70	φ15.88		
		inch	3/8	3/8	1/2	1/2	1/2	5/8		
Connectable Indoor Units	Quantity	pcs	13	16	19	23	26	29		
	Connection Ratio	—	50%~200%							
Piping Design	Max. Total Piping Length		m							
	Max. Piping Length	Actual Length	m							
		Equivalent Length	m							
	Height Difference Between ODU and IDU		m							
			When the ODU is above: 50(90°)							
	Height Difference Between IDUs		m							
When the ODU is below: 40(90°)										
Cooling Operating Range		°CDB	10~52							

NOTES:

- Rated capacity is tested in the following conditions:  
Cooling conditions: indoor air inlet temperature: 27°C DB 19°C WB, Outdoor air inlet temperature: 35°C DB, pipe length: 7.5m, pipe height difference: 0m
- The above noise values are measured in the anechoic chamber without reflected echo, therefore the impact of the reflected echo must be included at the scene.  
Measurement point: 1 meter from the service cover surface and 1.5 meters from floor level.

### Outdoor Unit Specifications



Capacity			20HP	22HP	24HP	26HP	28HP		
Model			AVWT-190CKFSE	AVWT-212CKFSE	AVWT-232CKFSE	AVWT-250CKFSE	AVWT-272CKFSE		
Combination			AVWT-190CKFSE	AVWT-212CKFSE	AVWT-232CKFSE	AVWT-250CKFSE	AVWT-272CKFSE		
Power Supply			AC 3Φ, 380-415V/50/60Hz						
Cooling Operation	Capacity	kW	56.0	61.5	68.0	72.5	80.0		
		kBtu/h	191.1	209.8	232.0	247.4	273.0		
	Power Input	kW	15.18	17.67	19.82	20.54	23.88		
	EER	W/W	3.69	3.48	3.43	3.53	3.35		
Ventilation	Air Flow Rate	m³/min	267	296	296	350	350		
	Fan Quantity	pcs	2	2	2	2	2		
	Static Pressure	Pa	110	110	110	110	110		
Sound Pressure Level(Normal/Silent)			dB(A)		63/47	64/48	65/48	66/50	67/50
Compressor	Type	—	Scroll Compressor						
	Quantity	pcs	2	2	2	2	2		
Refrigerant	Type	—	R410A						
	Pre-charged Quantity	kg	13.4	13.4	13.4	14.7	14.7		
Weight	Net Weight	kg	347	358	359	376	377		
	Gross Weight	kg	380	390	391	414	416		
Cabinet Color			Ivory White						
Net Dimensions	Height	mm	1730	1730	1730	1730	1730		
	Width	mm	1350	1350	1350	1600	1600		
	Depth	mm	750	750	750	750	750		
Packing Dimensions	Height	mm	1950	1950	1950	1950	1950		
	Width	mm	1420	1420	1420	1665	1665		
	Depth	mm	790	790	790	790	790		
Ref. Piping	Gas	mm	φ28.60	φ28.60	φ28.60	φ31.75	φ31.75		
		inch	1-1/8	1-1/8	1-1/8	1-1/4	1-1/4		
	Liquid	mm	φ15.88	φ15.88	φ15.88	φ19.05	φ19.05		
		inch	5/8	5/8	5/8	3/4	3/4		
Connectable Indoor Units	Quantity	pcs	33	36	40	43	47		
	Connection Ratio	—	50%~200%						
Piping Design	Max. Total Piping Length		m						
	Max. Piping Length	Actual Length	m						
		Equivalent Length	m						
	Height Difference Between ODU and IDU		m						
			When the ODU is above: 50(90°)						
	Height Difference Between IDUs		m						
When the ODU is below: 40(90°)									
Cooling Operating Range		°CDB	10~52						

NOTES:

- The final appearance of outdoor units is subject to the actual products.
- When the operation temperature is under 48°C DB ~ 52°C DB, please contact with our professional engineer.
- \*1: If height difference between ODU&IDU more than 50(40)m, please contact with our professional engineer.
- \*2: If the height difference between indoor units is more than 15m, please contact with our professional engineer.

## Standard Combination

### Outdoor Unit Specifications



Capacity			30HP	32HP	34HP	36HP	38HP
Model			AVWT-290CKFSE	AVWT-308CKFSE	AVWT-324CKFSE	AVWT-340CKFSE	AVWT-360CKFSE
Combination			AVWT-136CKFSE	AVWT-154CKFSE	AVWT-154CKFSE	AVWT-170CKFSE	AVWT-170CKFSE
			AVWT-154CKFSE	AVWT-154CKFSE	AVWT-170CKFSE	AVWT-170CKFSE	AVWT-190CKFSE
Power Supply			AC 3 $\phi$ , 380-415V/50/60Hz				
Cooling Operation	Capacity	kW	85.0	90.0	95.0	100.0	106.0
		kBtu/h	290	307	324.1	341.2	361.7
	Power Input	kW	22.34	24.32	26.13	27.94	29.15
	EER	W/W	3.80	3.70	3.64	3.58	3.64
Ventilation	Air Flow Rate	m <sup>3</sup> /min	400	400	400	400	467
	Fan Quantity	pcs	4	4	4	4	4
	Static Pressure	Pa	110	110	110	110	110
Sound Pressure Level(Normal/Silent)			65/48	65/48	66/49	66/49	66/50
Compressor	Type	—	Scroll Compressor				
	Quantity	pcs	2	2	2	2	3
Refrigerant	Type	—	R410A				
	Pre-charged Quantity	kg	10+10	10+10	10+12.3	12.3+12.3	12.3+13.4
Weight	Net Weight	kg	260+262	262+262	262+285	285+285	285+347
	Gross Weight	kg	291+293	293+293	293+315	315+315	315+380
Cabinet Color			Ivory White				
Net Dimensions	Height	mm	1730	1730	1730	1730	1730
	Width	mm	1210+1210	1210+1210	1210+1210	1210+1210	1210+1350
	Depth	mm	750	750	750	750	750
Packing Dimensions	Height	mm	1950	1950	1950	1950	1950
	Width	mm	1275+1275	1275+1275	1275+1275	1275+1275	1275+1420
	Depth	mm	790	790	790	790	790
Ref. Piping	Gas	mm	$\phi$ 31.75	$\phi$ 31.75	$\phi$ 38.1	$\phi$ 38.1	$\phi$ 38.1
		inch	1-1/4	1-1/4	1-1/2	1-1/2	1-1/2
	Liquid	mm	$\phi$ 19.05	$\phi$ 19.05	$\phi$ 19.05	$\phi$ 19.05	$\phi$ 19.05
		inch	3/4	3/4	3/4	3/4	3/4
Connectable Indoor Units	Quantity	pcs	49	52	55	59	62
	Connection Ratio	-	50%~180%				
Piping Design	Max. Total Piping Length		m				
	Max. Piping Length	Actual Length	m				
		Equivalent Length	m				
	Height Difference Between ODU and IDU		m				
			When the ODU is above: 50(90°)				
			When the ODU is below: 40(90°)				
Height Difference Between IDUs		m					
		15(30°)					
Cooling Operating Range		°CDB	10~52				

NOTES:

- Rated capacity is tested in the following conditions:  
Cooling conditions: indoor air inlet temperature: 27°C DB 19°C WB, Outdoor air inlet temperature: 35°C DB, pipe length: 7.5m, pipe height difference: 0m
- The above noise values are measured in the anechoic chamber without reflected echo, therefore the impact of the reflected echo must be included at the scene.  
Measurement point: 1 meter from the service cover surface and 1.5 meters from floor level.

### Outdoor Unit Specifications



Capacity			40HP	42HP	44HP	46HP	48HP
Model			AVWT-382CKFSE	AVWT-402CKFSE	AVWT-422CKFSE	AVWT-444CKFSE	AVWT-464CKFSE
Combination			AVWT-170CKFSE	AVWT-170CKFSE	AVWT-190CKFSE	AVWT-212CKFSE	AVWT-232CKFSE
			AVWT-212CKFSE	AVWT-232CKFSE	AVWT-232CKFSE	AVWT-232CKFSE	AVWT-232CKFSE
Power Supply			AC 3 $\phi$ , 380-415V/50/60Hz				
Cooling Operation	Capacity	kW	111.5	118.0	124.0	129.5	136.0
		kBtu/h	380.4	402.6	423.1	441.8	464.0
	Power Input	kW	31.64	33.79	35.00	37.49	39.64
	EER	W/W	3.52	3.49	3.54	3.45	3.43
Ventilation	Air Flow Rate	m <sup>3</sup> /min	496	496	563	592	592
	Fan Quantity	pcs	4	4	4	4	4
	Static Pressure	Pa	110	110	110	110	110
Sound Pressure Level(Normal/Silent)			67/50	67/50	67/51	68/51	68/51
Compressor	Type	—	Scroll Compressor				
	Quantity	pcs	3	3	4	4	4
Refrigerant	Type	—	R410A				
	Pre-charged Quantity	kg	12.3+13.4	12.3+13.4	13.4+13.4	13.4+13.4	13.4+13.4
Weight	Net Weight	kg	285+358	285+359	347+359	358+359	359+359
	Gross Weight	kg	315+390	315+391	380+391	390+391	391+391
Cabinet Color			Ivory White				
Net Dimensions	Height	mm	1730	1730	1730	1730	1730
	Width	mm	1210+1350	1210+1350	1350+1350	1350+1350	1350+1350
	Depth	mm	750	750	750	750	750
Packing Dimensions	Height	mm	1950	1950	1950	1950	1950
	Width	mm	1275+1420	1275+1420	1420+1420	1420+1420	1420+1420
	Depth	mm	790	790	790	790	790
Ref. Piping	Gas	mm	$\phi$ 38.1	$\phi$ 38.1	$\phi$ 38.1	$\phi$ 41.3	$\phi$ 41.3
		inch	1-1/2	1-1/2	1-1/2	1-5/8	1-5/8
	Liquid	mm	$\phi$ 19.05	$\phi$ 19.05	$\phi$ 19.05	$\phi$ 22.2	$\phi$ 22.2
		inch	3/4	3/4	3/4	7/8	7/8
Connectable Indoor Units	Quantity	pcs	64	64	64	64	64
	Connection Ratio	-	50%~180%				
Piping Design	Max. Total Piping Length		m				
	Max. Piping Length	Actual Length	m				
		Equivalent Length	m				
	Height Difference Between ODU and IDU		m				
			When the ODU is above: 50(90°)				
			When the ODU is below: 40(90°)				
Height Difference Between IDUs		m					
		15(30°)					
Cooling Operating Range		°CDB	10~52				

3. The final appearance of outdoor units is subject to the actual products.

- When the operation temperature is under 48°C DB ~ 52°C DB, please contact with our professional engineer.
- \*1: If height difference between ODU&IDU more than 50(40)m, please contact with our professional engineer.
- \*2: If the height difference between indoor units is more than 15m, please contact with our professional engineer.



## Standard Combination

### Outdoor Unit Specifications



Capacity			50HP	52HP	54HP	56HP
Model			AVWT-482CKFSE	AVWT-504CKFSE	AVWT-522CKFSE	AVWT-544CKFSE
Combination			AVWT-232CKFSE	AVWT-232CKFSE	AVWT-250CKFSE	AVWT-272CKFSE
			AVWT-250CKFSE	AVWT-272CKFSE	AVWT-272CKFSE	AVWT-272CKFSE
			/	/	/	/
Power Supply			AC 3 $\phi$ , 380-415V/50/60Hz			
Cooling Operation	Capacity	kW	140.5	148.0	152.5	160.0
		kBtu/h	479.4	505.0	520.4	546.0
	Power Input	kW	40.36	43.7	44.42	47.76
	EER	W/W	3.48	3.39	3.43	3.35
Ventilation	Air Flow Rate	m <sup>3</sup> /min	646	646	700	700
	Fan Quantity	pcs	4	4	4	4
	Static Pressure	Pa	110	110	110	110
Sound Pressure Level(Normal/Silent)		dB(A)	69/52	69/52	70/53	70/53
Compressor	Type	—	Scroll Compressor			
	Quantity	pcs	4	4	4	4
Refrigerant	Type	—	R410A			
	Pre-charged Quantity	kg	13.4+14.7	13.4+14.7	14.7+14.7	14.7+14.7
Weight	Net Weight	kg	359+376	359+377	376+377	377+377
	Gross Weight	kg	391+414	391+416	414+416	416+416
Cabinet Color		—	Ivory White			
Net Dimensions	Height	mm	1730	1730	1730	1730
	Width	mm	1350+1600	1350+1600	1600+1600	1600+1600
	Depth	mm	750	750	750	750
Packing Dimensions	Height	mm	1950	1950	1950	1950
	Width	mm	1420+1665	1420+1665	1665+1665	1665+1665
	Depth	mm	790	790	790	790
Ref. Piping	Gas	mm	$\phi$ 41.3	$\phi$ 41.3	$\phi$ 41.3	$\phi$ 41.3
		inch	1-5/8	1-5/8	1-5/8	1-5/8
	Liquid	mm	$\phi$ 22.2	$\phi$ 22.2	$\phi$ 22.2	$\phi$ 22.2
		inch	7/8	7/8	7/8	7/8
Connectable Indoor Units	Quantity	pcs	64	64	64	64
	Connection Ratio	—	50%~180%			
Piping Design	Max. Total Piping Length		m			
	Max. Piping Length	Actual Length	m			
		Equivalent Length	m			
	Height Difference Between ODU and IDU		m			
			When the ODU is above: 50(90°*)			
	Height Difference Between IDUs		m			
When the ODU is below: 40(90°*)						
Cooling Operating Range		°CDB	10~52			

NOTES:

- Rated capacity is tested in the following conditions:  
Cooling conditions: indoor air inlet temperature: 27°C DB 19°C WB, Outdoor air inlet temperature: 35°C DB, pipe length: 7.5m, pipe height difference: 0m
- The above noise values are measured in the anechoic chamber without reflected echo, therefore the impact of the reflected echo must be included at the scene.  
Measurement point: 1 meter from the service cover surface and 1.5 meters from floor level.

### Outdoor Unit Specifications



Capacity			58HP	60HP	62HP	64HP
Model			AVWT-552CKFSE	AVWT-572CKFSE	AVWT-592CKFSE	AVWT-614CKFSE
Combination			AVWT-170CKFSE	AVWT-170CKFSE	AVWT-170CKFSE	AVWT-170CKFSE
			AVWT-170CKFSE	AVWT-170CKFSE	AVWT-190CKFSE	AVWT-212CKFSE
			AVWT-212CKFSE	AVWT-232CKFSE	AVWT-232CKFSE	AVWT-232CKFSE
			/	/	/	/
Power Supply			AC 3 $\phi$ , 380-415V/50/60Hz			
Cooling Operation	Capacity	kW	161.5	168.0	174.0	179.5
		kBtu/h	551.0	573.2	593.7	612.4
	Power Input	kW	45.61	47.76	48.97	51.46
	EER	W/W	3.54	3.52	3.55	3.49
Ventilation	Air Flow Rate	m <sup>3</sup> /min	696	696	763	792
	Fan Quantity	pcs	6	6	6	6
	Static Pressure	Pa	110	110	110	110
Sound Pressure Level(Normal/Silent)		dB(A)	68/52	69/52	69/52	69/52
Compressor	Type	—	Scroll Compressor			
	Quantity	pcs	4	4	5	5
Refrigerant	Type	—	R410A			
	Pre-charged Quantity	kg	12.3+12.3+13.4	12.3+12.3+13.4	12.3+13.4+13.4	12.3+13.4+13.4
Weight	Net Weight	kg	285+285+358	285+347+359	285+347+359	285+358+359
	Gross Weight	kg	315+315+390	315+315+391	315+380+391	315+390+391
Cabinet Color		—	Ivory White			
Net Dimensions	Height	mm	1730	1730	1730	1730
	Width	mm	1210+1210+1350	1210+1210+1350	1210+1350+1350	1210+1350+1350
	Depth	mm	750	750	750	750
Packing Dimensions	Height	mm	1950	1950	1950	1950
	Width	mm	1275+1275+1420	1275+1275+1420	1275+1420+1420	1275+1420+1420
	Depth	mm	790	790	790	790
Ref. Piping	Gas	mm	$\phi$ 44.5	$\phi$ 44.5	$\phi$ 44.5	$\phi$ 44.5
		inch	1-3/4	1-3/4	1-3/4	1-3/4
	Liquid	mm	$\phi$ 22.2	$\phi$ 22.2	$\phi$ 22.2	$\phi$ 22.2
		inch	7/8	7/8	7/8	7/8
Connectable Indoor Units	Quantity	pcs	64	64	64	64
	Connection Ratio	—	50%~160%			
Piping Design	Max. Total Piping Length		m			
	Max. Piping Length	Actual Length	m			
		Equivalent Length	m			
	Height Difference Between ODU and IDU		m			
			When the ODU is above: 50(90°*)			
	Height Difference Between IDUs		m			
When the ODU is below: 40(90°*)						
Cooling Operating Range		°CDB	10~52			

3. The final appearance of outdoor units is subject to the actual products.

- When the operation temperature is under 48°C DB ~ 52°C DB, please contact with our professional engineer.
- \*1: If height difference between ODU&IDU more than 50(40)m, please contact with our professional engineer.
- \*2: If the height difference between indoor units is more than 15m, please contact with our professional engineer.

## Standard Combination

### Outdoor Unit Specifications



Capacity			66HP	68HP	70HP	72HP
Model			AVWT-634CKFSE	AVWT-654CKFSE	AVWT-676CKFSE	AVWT-696CKFSE
Combination			AVWT-170CKFSE	AVWT-190CKFSE	AVWT-212CKFSE	AVWT-232CKFSE
			AVWT-232CKFSE	AVWT-232CKFSE	AVWT-232CKFSE	AVWT-232CKFSE
			/	/	/	/
Power Supply			AC 3 $\phi$ , 380-415V/50/60Hz			
Cooling Operation	Capacity	kW	186.0	192.0	197.5	204.0
		kBtu/h	634.6	655.1	673.8	696.0
	Power Input	kW	53.61	54.82	57.31	59.46
	EER	W/W	3.47	3.50	3.45	3.43
Ventilation	Air Flow Rate	m <sup>3</sup> /min	792	859	888	888
	Fan Quantity	pcs	6	6	6	6
	Static Pressure	Pa	110	110	110	110
Sound Pressure Level(Normal/Silent)			69/52	69/52	69/53	70/53
Compressor	Type	—	Scroll Compressor			
	Quantity	pcs	5	6	6	6
Refrigerant	Type	—	R410A			
	Pre-charged Quantity	kg	12.3+13.4+13.4	13.4+13.4+13.4	13.4+13.4+13.4	13.4+13.4+13.4
Weight	Net Weight	kg	285+359+359	347+359+359	358+359+359	359+359+359
	Gross Weight	kg	315+391+391	380+391+391	390+391+391	391+391+391
Cabinet Color			Ivory White			
Net Dimensions	Height	mm	1730	1730	1730	1730
	Width	mm	1210+1350+1350	1350+1350+1350	1350+1350+1350	1350+1350+1350
	Depth	mm	750	750	750	750
Packing Dimensions	Height	mm	1950	1950	1950	1950
	Width	mm	1275+1420+1420	1420+1420+1420	1420+1420+1420	1420+1420+1420
	Depth	mm	790	790	790	790
Ref. Piping	Gas	mm	$\phi$ 44.5	$\phi$ 50.8	$\phi$ 50.8	$\phi$ 50.8
		inch	1-3/4	2	2	2
	Liquid	mm	$\phi$ 22.2	$\phi$ 25.4	$\phi$ 25.4	$\phi$ 25.4
		inch	7/8	1	1	1
Connectable Indoor Units	Quantity	pcs	64	64	64	64
	Connection Ratio	—	50%~160%			
Piping Design	Max. Total Piping Length		m			
	Max. Piping Length	Actual Length	m			
		Equivalent Length	m			
	Height Difference Between ODU and IDU		m			
	Height Difference Between IDUs		m			
Cooling Operating Range		°CDB	10~52			

NOTES:

- Rated capacity is tested in the following conditions:  
Cooling conditions: indoor air inlet temperature: 27°C DB 19°C WB, Outdoor air inlet temperature: 35°C DB, pipe length: 7.5m, pipe height difference: 0m
- The above noise values are measured in the anechoic chamber without reflected echo, therefore the impact of the reflected echo must be included at the scene.  
Measurement point: 1 meter from the service cover surface and 1.5 meters from floor level.

### Outdoor Unit Specifications



Capacity			74HP	76HP	78HP	80HP
Model			AVWT-714CKFSE	AVWT-732CKFSE	AVWT-754CKFSE	AVWT-776CKFSE
Combination			AVWT-232CKFSE	AVWT-232CKFSE	AVWT-232CKFSE	AVWT-232CKFSE
			AVWT-232CKFSE	AVWT-250CKFSE	AVWT-250CKFSE	AVWT-272CKFSE
			AVWT-250CKFSE	AVWT-250CKFSE	AVWT-272CKFSE	AVWT-272CKFSE
			/	/	/	/
Power Supply			AC 3 $\phi$ , 380-415V/50/60Hz			
Cooling Operation	Capacity	kW	208.5	213.0	220.5	228.0
		kBtu/h	711.4	726.8	752.4	778.0
	Power Input	kW	60.18	60.90	64.24	67.58
	EER	W/W	3.46	3.50	3.43	3.37
Ventilation	Air Flow Rate	m <sup>3</sup> /min	942	996	996	996
	Fan Quantity	pcs	6	6	6	6
	Static Pressure	Pa	110	110	110	110
Sound Pressure Level(Normal/Silent)			70/54	70/54	71/54	71/54
Compressor	Type	—	Scroll Compressor			
	Quantity	pcs	6	6	6	6
Refrigerant	Type	—	R410A			
	Pre-charged Quantity	kg	13.4+13.4+14.7	13.4+14.7+14.7	13.4+14.7+14.7	13.4+14.7+14.7
Weight	Net Weight	kg	359+359+376	359+376+376	359+376+377	359+377+377
	Gross Weight	kg	391+391+414	391+414+414	391+414+416	391+416+416
Cabinet Color			Ivory White			
Net Dimensions	Height	mm	1730	1730	1730	1730
	Width	mm	1350+1350+1600	1350+1600+1600	1350+1600+1600	1350+1600+1600
	Depth	mm	750	750	750	750
Packing Dimensions	Height	mm	1950	1950	1950	1950
	Width	mm	1420+1420+1665	1420+1665+1665	1420+1665+1665	1420+1665+1665
	Depth	mm	790	790	790	790
Ref. Piping	Gas	mm	$\phi$ 50.8	$\phi$ 50.8	$\phi$ 50.8	$\phi$ 50.8
		inch	2	2	2	2
	Liquid	mm	$\phi$ 25.4	$\phi$ 25.4	$\phi$ 25.4	$\phi$ 25.4
		inch	1	1	1	1
Connectable Indoor Units	Quantity	pcs	64	64	64	64
	Connection Ratio	—	50%~160%			
Piping Design	Max. Total Piping Length		m			
	Max. Piping Length	Actual Length	m			
		Equivalent Length	m			
	Height Difference Between ODU and IDU		m			
	Height Difference Between IDUs		m			
Cooling Operating Range		°CDB	10~52			

NOTES:

- The final appearance of outdoor units is subject to the actual products.
- When the operation temperature is under 48°C DB ~ 52°C DB, please contact with our professional engineer.
- \*1: If height difference between ODU&IDU more than 50(40)m, please contact with our professional engineer.
- \*2: If the height difference between indoor units is more than 15m, please contact with our professional engineer.

## Standard Combination

### Outdoor Unit Specifications



Capacity			82HP	84HP	86HP	88HP
Model			AVWT-794CKFSE	AVWT-816CKFSE	AVWT-824CKFSE	AVWT-844CKFSE
Combination			AVWT-250CKFSE	AVWT-272CKFSE	AVWT-190CKFSE	AVWT-190CKFSE
			AVWT-272CKFSE	AVWT-272CKFSE	AVWT-190CKFSE	AVWT-190CKFSE
			AVWT-272CKFSE	AVWT-272CKFSE	AVWT-212CKFSE	AVWT-232CKFSE
			/	/	AVWT-232CKFSE	AVWT-232CKFSE
Power Supply			AC 3Φ, 380-415V/50/60Hz			
Cooling Operation	Capacity	kW	232.5	240.0	241.5	248.0
		kBtu/h	793.4	819.0	824.0	846.2
	Power Input	kW	68.30	71.64	67.85	70.00
	EER	W/W	3.40	3.35	3.56	3.54
Ventilation	Air Flow Rate	m³/min	1050	1050	1126	1126
	Fan Quantity	pcs	6	6	8	8
	Static Pressure	Pa	110	110	110	110
Sound Pressure Level(Normal/Silent)			dB(A)		71/55	72/55
Compressor	Type	Scroll Compressor				
	Quantity	pcs	6	6	8	8
Refrigerant	Type	R410A				
	Pre-charged Quantity	kg	14.7+14.7+14.7	14.7+14.7+14.7	13.4+13.4+13.4+13.4	13.4+13.4+13.4+13.4
Weight	Net Weight	kg	376+377+377	377+377+377	347+347+358+359	347+347+359+359
	Gross Weight	kg	414+416+416	416+416+416	380+380+390+391	380+380+391+391
Cabinet Color			Ivory White			
Net Dimensions	Height	mm	1730	1730	1730	1730
	Width	mm	1600+1600+1600	1600+1600+1600	1350+1350+1350+1350	1350+1350+1350+1350
	Depth	mm	750	750	750	750
Packing Dimensions	Height	mm	1950	1950	1950	1950
	Width	mm	1665+1665+1665	1665+1665+1665	1420+1420+1420+1420	1420+1420+1420+1420
	Depth	mm	790	790	790	790
Ref. Piping	Gas	mm	φ50.8	φ50.8	φ50.8	φ50.8
		inch	2	2	2	2
	Liquid	mm	φ25.4	φ25.4	φ25.4	φ25.4
inch		1	1	1	1	
Connectable Indoor Units	Quantity	pcs	64	64	64	64
	Connection Ratio	-	50%-160%		50%-150%	
Piping Design	Max. Total Piping Length		m			
	Max. Piping Length	Actual Length	m			
		Equivalent Length	m			
	Height Difference Between ODU and IDU		m			
			When the ODU is above: 50(90°*)			
Height Difference Between IDUs		m				
		When the ODU is below: 40(90°*)				
Cooling Operating Range		°CDB	10-52			

NOTES:

- Rated capacity is tested in the following conditions:  
Cooling conditions: indoor air inlet temperature: 27°C DB 19°C WB, Outdoor air inlet temperature: 35°C DB, pipe length: 7.5m, pipe height difference: 0m
- The above noise values are measured in the anechoic chamber without reflected echo, therefore the impact of the reflected echo must be included at the scene.  
Measurement point: 1 meter from the service cover surface and 1.5 meters from floor level.

### Outdoor Unit Specifications



Capacity			90HP	92HP	94HP	96HP
Model			AVWT-866CKFSE	AVWT-886CKFSE	AVWT-908CKFSE	AVWT-928CKFSE
Combination			AVWT-190CKFSE	AVWT-190CKFSE	AVWT-212CKFSE	AVWT-232CKFSE
			AVWT-212CKFSE	AVWT-232CKFSE	AVWT-232CKFSE	AVWT-232CKFSE
			AVWT-232CKFSE	AVWT-232CKFSE	AVWT-232CKFSE	AVWT-232CKFSE
			AVWT-232CKFSE	AVWT-232CKFSE	AVWT-232CKFSE	AVWT-232CKFSE
Power Supply			AC 3Φ, 380-415V/50/60Hz			
Cooling Operation	Capacity	kW	253.5	260.0	265.5	272.0
		kBtu/h	864.9	887.1	905.8	928.0
	Power Input	kW	72.49	74.64	77.13	79.28
	EER	W/W	3.50	3.48	3.44	3.43
Ventilation	Air Flow Rate	m³/min	1155	1155	1184	1184
	Fan Quantity	pcs	8	8	8	8
	Static Pressure	Pa	110	110	110	110
Sound Pressure Level(Normal/Silent)			dB(A)		70/54	71/54
Compressor	Type	Scroll Compressor				
	Quantity	pcs	8	8	8	8
Refrigerant	Type	R410A				
	Pre-charged Quantity	kg	13.4+13.4+13.4+13.4	13.4+13.4+13.4+13.4	13.4+13.4+13.4+13.4	13.4+13.4+13.4+13.4
Weight	Net Weight	kg	347+358+359+359	347+359+359+359	358+359+359+359	359+359+359+359
	Gross Weight	kg	380+390+391+391	380+391+391+391	390+391+391+391	391+391+391+391
Cabinet Color			Ivory White			
Net Dimensions	Height	mm	1730	1730	1730	1730
	Width	mm	1350+1350+1350+1350	1350+1350+1350+1350	1350+1350+1350+1350	1350+1350+1350+1350
	Depth	mm	750	750	750	750
Packing Dimensions	Height	mm	1950	1950	1950	1950
	Width	mm	1420+1420+1420+1420	1420+1420+1420+1420	1420+1420+1420+1420	1420+1420+1420+1420
	Depth	mm	790	790	790	790
Ref. Piping	Gas	mm	φ50.8	φ50.8	φ50.8	φ50.8
		inch	2	2	2	2
	Liquid	mm	φ25.4	φ25.4	φ25.4	φ25.4
inch		1	1	1	1	
Connectable Indoor Units	Quantity	pcs	64	64	64	64
	Connection Ratio	-	50%-150%			
Piping Design	Max. Total Piping Length		m			
	Max. Piping Length	Actual Length	m			
		Equivalent Length	m			
	Height Difference Between ODU and IDU		m			
			When the ODU is above: 50(90°*)			
Height Difference Between IDUs		m				
		When the ODU is below: 40(90°*)				
Cooling Operating Range		°CDB	10-52			

3. The final appearance of outdoor units is subject to the actual products.

- When the operation temperature is under 48°C DB ~ 52°C DB, please contact with our professional engineer.
- \*1: If height difference between ODU&IDU more than 50(40)m, please contact with our professional engineer.
- \*2: If the height difference between indoor units is more than 15m, please contact with our professional engineer.

## Standard Combination

### Outdoor Unit Specifications



Capacity			98HP	100HP	102HP	104HP
Model			AVWT-946CKFSE	AVWT-968CKFSE	AVWT-986CKFSE	AVWT-1008CKFSE
Combination			AVWT-232CKFSE	AVWT-232CKFSE	AVWT-232CKFSE	AVWT-232CKFSE
			AVWT-232CKFSE	AVWT-232CKFSE	AVWT-232CKFSE	AVWT-232CKFSE
			AVWT-232CKFSE	AVWT-232CKFSE	AVWT-250CKFSE	AVWT-272CKFSE
			AVWT-250CKFSE	AVWT-272CKFSE	AVWT-272CKFSE	AVWT-272CKFSE
Power Supply			AC 3 $\phi$ , 380-415V/50/60Hz			
Cooling Operation	Capacity	kW	276.5	284.0	288.5	296.0
		kBtu/h	943.4	969.0	984.4	1010.0
	Power Input	kW	80.00	83.34	84.06	87.40
	EER	W/W	3.46	3.41	3.43	3.39
Ventilation	Air Flow Rate	m <sup>3</sup> /min	1238	1238	1292	1292
	Fan Quantity	pcs	8	8	8	8
	Static Pressure	Pa	110	110	110	110
Sound Pressure Level(Normal/Silent)			dB(A)			
			71/55	72/55	72/55	72/55
Compressor	Type	—	Scroll Compressor			
	Quantity	pcs	8	8	8	8
Refrigerant	Type	—	R410A			
	Pre-charged Quantity	kg	13.4+13.4+13.4+14.7	13.4+13.4+13.4+14.7	13.4+13.4+14.7+14.7	13.4+13.4+14.7+14.7
Weight	Net Weight	kg	359+359+359+376	359+359+359+377	359+359+376+377	359+359+377+377
	Gross Weight	kg	391+391+391+414	391+391+391+416	391+391+414+416	391+391+416+416
Cabinet Color			Ivory White			
Net Dimensions	Height	mm	1730	1730	1730	1730
	Width	mm	1350+1350+1350+1600	1350+1350+1350+1600	1350+1350+1600+1600	1350+1350+1600+1600
	Depth	mm	750	750	750	750
Packing Dimensions	Height	mm	1950	1950	1950	1950
	Width	mm	1420+1420+1420+1665	1420+1420+1420+1665	1420+1420+1665+1665	1420+1420+1665+1665
	Depth	mm	790	790	790	790
Ref. Piping	Gas	mm	$\phi$ 50.8	$\phi$ 50.8	$\phi$ 50.8	$\phi$ 50.8
		inch	2	2	2	2
	Liquid	mm	$\phi$ 25.4	$\phi$ 25.4	$\phi$ 25.4	$\phi$ 25.4
		inch	1	1	1	1
Connectable Indoor Units	Quantity	pcs	64	64	64	64
	Connection Ratio	—	50%~150%			
Piping Design	Max. Total Piping Length		m			
	Max. Piping Length	Actual Length	m			
		Equivalent Length	m			
	Height Difference Between ODU and IDU		m			
			When the ODU is above: 50(90°)			
Height Difference Between IDUs		m				
		When the ODU is below: 40(90°)				
Cooling Operating Range		°CDB	10~52			

NOTES:

- Rated capacity is tested in the following conditions:  
Cooling conditions: indoor air inlet temperature: 27°C DB 19°C WB, Outdoor air inlet temperature: 35°C DB, pipe length: 7.5m, pipe height difference: 0m
- The above noise values are measured in the anechoic chamber without reflected echo, therefore the impact of the reflected echo must be included at the scene.  
Measurement point: 1 meter from the service cover surface and 1.5 meters from floor level.

### Outdoor Unit Specifications



Capacity			106HP	108HP	110HP	112HP
Model			AVWT-1026CKFSE	AVWT-1048CKFSE	AVWT-1066CKFSE	AVWT-1088CKFSE
Combination			AVWT-232CKFSE	AVWT-232CKFSE	AVWT-250CKFSE	AVWT-272CKFSE
			AVWT-250CKFSE	AVWT-272CKFSE	AVWT-272CKFSE	AVWT-272CKFSE
			AVWT-272CKFSE	AVWT-272CKFSE	AVWT-272CKFSE	AVWT-272CKFSE
			AVWT-272CKFSE	AVWT-272CKFSE	AVWT-272CKFSE	AVWT-272CKFSE
Power Supply			AC 3 $\phi$ , 380-415V/50/60Hz			
Cooling Operation	Capacity	kW	300.5	308.0	312.5	320.0
		kBtu/h	1025.4	1051.0	1066.4	1092.0
	Power Input	kW	88.12	91.46	92.18	95.52
	EER	W/W	3.41	3.37	3.39	3.35
Ventilation	Air Flow Rate	m <sup>3</sup> /min	1346	1346	1400	1400
	Fan Quantity	pcs	8	8	8	8
	Static Pressure	Pa	110	110	110	110
Sound Pressure Level(Normal/Silent)			dB(A)			
			72/56	73/56	73/56	73/56
Compressor	Type	—	Scroll Compressor			
	Quantity	pcs	8	8	8	8
Refrigerant	Type	—	R410A			
	Pre-charged Quantity	kg	13.4+14.7+14.7+14.7	13.4+14.7+14.7+14.7	14.7+14.7+14.7+14.7	14.7+14.7+14.7+14.7
Weight	Net Weight	kg	359+376+377+377	359+377+377+377	376+377+377+377	377+377+377+377
	Gross Weight	kg	391+414+416+416	391+416+416+416	414+416+416+416	416+416+416+416
Cabinet Color			Ivory White			
Net Dimensions	Height	mm	1730	1730	1730	1730
	Width	mm	1350+1600+1600+1600	1350+1600+1600+1600	1600+1600+1600+1600	1600+1600+1600+1600
	Depth	mm	750	750	750	750
Packing Dimensions	Height	mm	1950	1950	1950	1950
	Width	mm	1420+1665+1665+1665	1420+1665+1665+1665	1665+1665+1665+1665	1665+1665+1665+1665
	Depth	mm	790	790	790	790
Ref. Piping	Gas	mm	$\phi$ 50.8	$\phi$ 50.8	$\phi$ 50.8	$\phi$ 50.8
		inch	2	2	2	2
	Liquid	mm	$\phi$ 25.4	$\phi$ 25.4	$\phi$ 25.4	$\phi$ 25.4
		inch	1	1	1	1
Connectable Indoor Units	Quantity	pcs	64	64	64	64
	Connection Ratio	—	50%~150%			
Piping Design	Max. Total Piping Length		m			
	Max. Piping Length	Actual Length	m			
		Equivalent Length	m			
	Height Difference Between ODU and IDU		m			
			When the ODU is above: 50(90°)			
Height Difference Between IDUs		m				
		When the ODU is below: 40(90°)				
Cooling Operating Range		°CDB	10~52			

NOTES:

- The final appearance of outdoor units is subject to the actual products.
- When the operation temperature is under 48°C DB ~ 52°C DB, please contact with our professional engineer.
- \*1: If height difference between ODU&IDU more than 50(40)m, please contact with our professional engineer.
- \*2: If the height difference between indoor units is more than 15m, please contact with our professional engineer.

## High-efficiency Combination

### Outdoor Unit Specifications



Capacity			16HP	18HP	20HP	22HP	24HP
Model			AVWT-152CKFSH	AVWT-172CKFSH	AVWT-192CKFSH	AVWT-210CKFSH	AVWT-228CKFSH
Combination			AVWT-76CKFSE	AVWT-76CKFSE	AVWT-96CKFSE	AVWT-96CKFSE	AVWT-114CKFSE
			AVWT-76CKFSE	AVWT-96CKFSE	AVWT-114CKFSE	AVWT-114CKFSE	AVWT-114CKFSE
Power Supply			AC 3Φ, 380-415V/50/60Hz				
Cooling Operation	Capacity	kW	44.8	50.4	56.0	61.5	67.0
		kBtu/h	152.8	171.9	191.0	209.8	228.6
	Power Input	kW	9.62	11.35	13.08	14.46	15.84
	EER	W/W	4.66	4.44	4.28	4.25	4.23
Ventilation	Air Flow Rate	m <sup>3</sup> /min	366	366	366	366	366
	Fan Quantity	pcs	2	2	2	2	2
	Static Pressure	Pa	110	110	110	110	110
Sound Pressure Level(Normal/Silent)			62/45	63/45	64/45	64/46	64/47
Compressor	Type	—	Scroll Compressor				
	Quantity	pcs	2	2	2	2	2
Refrigerant	Type	—	R410A				
	Pre-charged Quantity	kg	6.4+6.4	6.4+6.4	6.4+6.4	6.4+7.8	7.8+7.8
Weight	Net Weight	kg	212+212	212+213	213+213	213+218	218+218
	Gross Weight	kg	240+240	240+241	241+241	241+246	246+246
Cabinet Color			Ivory White				
Net Dimensions	Height	mm	1730	1730	1730	1730	1730
	Width	mm	950+950	950+950	950+950	950+950	950+950
	Depth	mm	750	750	750	750	750
Packing Dimensions	Height	mm	1950	1950	1950	1950	1950
	Width	mm	1015+1015	1015+1015	1015+1015	1015+1015	1015+1015
	Depth	mm	790	790	790	790	790
Ref. Piping	Gas	mm	φ28.60	φ28.60	φ28.60	φ28.60	φ28.60
		inch	1-1/8	1-1/8	1-1/8	1-1/8	1-1/8
	Liquid	mm	φ12.70	φ15.88	φ15.88	φ15.88	φ15.88
		inch	1/2	5/8	5/8	5/8	5/8
Connectable Indoor Units	Quantity	pcs	26	29	33	36	40
	Connection Ratio	—	50%~180%				
Piping Design	Max. Total Piping Length		m				
	Max. Piping Length	Actual Length	m				
		Equivalent Length	m				
	Height Difference Between ODU and IDU		m				
			When the ODU is above: 50(90°)				
			When the ODU is below: 40(90°)				
Height Difference Between IDUs		m					
		15(30°)					
Cooling Operating Range		°CDB	10~52				

NOTES:

- Rated capacity is tested in the following conditions:  
Cooling conditions: indoor air inlet temperature: 27°C DB 19°C WB, Outdoor air inlet temperature: 35°C DB, pipe length: 7.5m, pipe height difference: 0m
- The above noise values are measured in the anechoic chamber without reflected echo, therefore the impact of the reflected echo must be included at the scene.  
Measurement point: 1 meter from the service cover surface and 1.5 meters from floor level.

### Outdoor Unit Specifications



Capacity			26HP	28HP	30HP	32HP	34HP
Model			AVWT-250CKFSH	AVWT-268CKFSH	AVWT-288CKFSH	AVWT-306CKFSH	AVWT-324CKFSH
Combination			AVWT-114CKFSE	AVWT-76CKFSE	AVWT-96CKFSE	AVWT-96CKFSE	AVWT-96CKFSE
			AVWT-136CKFSE	AVWT-96CKFSE	AVWT-96CKFSE	AVWT-96CKFSE	AVWT-114CKFSE
Power Supply			AC 3Φ, 380-415V/50/60Hz				
Cooling Operation	Capacity	kW	73.5	78.4	84.0	89.5	95.0
		kBtu/h	250.8	267.4	286.5	305.3	324.1
	Power Input	kW	18.10	17.89	19.62	21.00	22.38
	EER	W/W	4.06	4.38	4.28	4.26	4.24
Ventilation	Air Flow Rate	m <sup>3</sup> /min	383	549	549	549	549
	Fan Quantity	pcs	3	3	3	3	3
	Static Pressure	Pa	110	110	110	110	110
Sound Pressure Level(Normal/Silent)			65/47	65/47	66/47	66/48	66/48
Compressor	Type	—	Scroll Compressor				
	Quantity	pcs	2	3	3	3	3
Refrigerant	Type	—	R410A				
	Pre-charged Quantity	kg	7.8+10.0	6.4+6.4+6.4	6.4+6.4+6.4	6.4+6.4+7.8	6.4+7.8+7.8
Weight	Net Weight	kg	218+260	212+213+213	213+213+213	213+213+218	213+218+218
	Gross Weight	kg	246+291	240+241+241	241+241+241	241+241+246	241+246+246
Cabinet Color			Ivory White				
Net Dimensions	Height	mm	1730	1730	1730	1730	1730
	Width	mm	950+1210	950+950+950	950+950+950	950+950+950	950+950+950
	Depth	mm	750	750	750	750	750
Packing Dimensions	Height	mm	1950	1950	1950	1950	1950
	Width	mm	1015+1275	1015+1015+1015	1015+1015+1015	1015+1015+1015	1015+1015+1015
	Depth	mm	790	790	790	790	790
Ref. Piping	Gas	mm	φ31.75	φ31.75	φ31.75	φ31.75	φ38.1
		inch	1-1/4	1-1/4	1-1/4	1-1/4	1-1/2
	Liquid	mm	φ19.05	φ19.05	φ19.05	φ19.05	φ19.05
		inch	3/4	3/4	3/4	3/4	3/4
Connectable Indoor Units	Quantity	pcs	43	47	50	53	56
	Connection Ratio	—	50%~180%	50%~160%			
Piping Design	Max. Total Piping Length		m				
	Max. Piping Length	Actual Length	m				
		Equivalent Length	m				
	Height Difference Between ODU and IDU		m				
			When the ODU is above: 50(90°)				
			When the ODU is below: 40(90°)				
Height Difference Between IDUs		m					
		15(30°)					
Cooling Operating Range		°CDB	10~52				

3. The final appearance of outdoor units is subject to the actual products.

- When the operation temperature is under 48°C DB ~ 52°C DB, please contact with our professional engineer.
- \*1: If height difference between ODU&IDU more than 50(40)m, please contact with our professional engineer.
- \*2: If the height difference between indoor units is more than 15m, please contact with our professional engineer.

## High-efficiency Combination

### Outdoor Unit Specifications



Capacity		36HP	38HP	40HP	42HP	44HP	
Model		AVWT-342CKFSH	AVWT-364CKFSH	AVWT-386CKFSH	AVWT-402CKFSH	AVWT-420CKFSH	
Combination		AVWT-114CKFSE	AVWT-114CKFSE	AVWT-114CKFSE	AVWT-96CKFSE	AVWT-96CKFSE	
		AVWT-114CKFSE	AVWT-114CKFSE	AVWT-136CKFSE	AVWT-96CKFSE	AVWT-96CKFSE	
		AVWT-114CKFSE	AVWT-136CKFSE	AVWT-136CKFSE	AVWT-96CKFSE	AVWT-114CKFSE	
Power Supply		/	/	/	AVWT-114CKFSE	AVWT-114CKFSE	
Cooling Operation		AC 3 φ, 380-415V/50/60Hz					
Cooling Operation	Capacity	kW	100.5	107.0	113.5	117.5	123.0
		kBtu/h	342.9	365.1	387.3	400.8	419.6
	Power Input	kW	23.76	26.02	28.28	27.54	28.92
	EER	W/W	4.23	4.11	4.01	4.27	4.25
Ventilation	Air Flow Rate	m <sup>3</sup> /min	549	566	583	732	732
	Fan Quantity	pcs	3	4	5	4	4
	Static Pressure	Pa	110	110	110	110	110
Sound Pressure Level(Normal/Silent)		dB(A)	66/49	66/49	66/49	67/49	67/49
Compressor	Type	Scroll Compressor					
	Quantity	pcs	3	3	3	4	4
Refrigerant	Type	R410A					
	Pre-charged Quantity	kg	7.8+7.8+7.8	7.8+7.8+10.0	7.8+10.0+10.0	6.4+6.4+6.4+7.8	6.4+6.4+7.8+7.8
Weight	Net Weight	kg	218+218+218	218+260+260	213+213+213+218	213+213+218+218	213+213+218+218
	Gross Weight	kg	246+246+246	246+246+291	246+291+291	241+241+241+246	241+241+246+246
Cabinet Color		Ivory White					
Net Dimensions	Height	mm	1730	1730	1730	1730	1730
	Width	mm	950+950+950	950+950+1210	950+1210+1210	950+950+950+950	950+950+950+950
	Depth	mm	750	750	750	750	750
Packing Dimensions	Height	mm	1950	1950	1950	1950	1950
	Width	mm	1015+1015+1015	1015+1015+1275	1015+1275+1275	1015+1015+1015+1015	1015+1015+1015+1015
	Depth	mm	790	790	790	790	790
Ref. Piping	Gas	mm	φ38.1	φ38.1	φ38.1	φ38.1	φ38.1
		inch	1-1/2	1-1/2	1-1/2	1-1/2	1-1/2
	Liquid	mm	φ19.05	φ19.05	φ19.05	φ19.05	φ19.05
		inch	3/4	3/4	3/4	3/4	3/4
Connectable Indoor Units	Quantity	pcs	59	64	64	64	64
	Connection Ratio	-	50%~160%		50%~150%		
Piping Design	Max. Total Piping Length		m				1000.0
	Max. Piping Length	Actual Length	m				165.0
		Equivalent Length	m				190.0
	Height Difference Between ODU and IDU		m				When the ODU is above: 50(90°)
			m				When the ODU is below: 40(90°)
Height Difference Between IDUs		m				15(30°)	
Cooling Operating Range		°CDB	10-52				

NOTES:

- Rated capacity is tested in the following conditions:  
Cooling conditions: indoor air inlet temperature: 27°C DB 19°C WB, Outdoor air inlet temperature: 35°C DB, pipe length: 7.5m, pipe height difference: 0m
- The above noise values are measured in the anechoic chamber without reflected echo, therefore the impact of the reflected echo must be included at the scene.  
Measurement point: 1 meter from the service cover surface and 1.5 meters from floor level.

### Outdoor Unit Specifications



Capacity		46HP	48HP	50HP	
Model		AVWT-438CKFSH	AVWT-456CKFSH	AVWT-478CKFSH	
Combination		AVWT-96CKFSE	AVWT-114CKFSE	AVWT-114CKFSE	
		AVWT-114CKFSE	AVWT-114CKFSE	AVWT-114CKFSE	
		AVWT-114CKFSE	AVWT-114CKFSE	AVWT-136CKFSE	
Power Supply		AC 3 φ, 380-415V/50/60Hz			
Cooling Operation	Capacity	kW	128.5	134.0	140.5
		kBtu/h	438.4	457.2	479.4
	Power Input	kW	30.30	31.68	33.94
	EER	W/W	4.24	4.23	4.14
Ventilation	Air Flow Rate	m <sup>3</sup> /min	732	732	749
	Fan Quantity	pcs	4	4	5
	Static Pressure	Pa	110	110	110
Sound Pressure Level(Normal/Silent)		dB(A)	67/50	67/50	67/50
Compressor	Type	Scroll Compressor			
	Quantity	pcs	4	4	4
Refrigerant	Type	R410A			
	Pre-charged Quantity	kg	6.4+7.8+7.8+7.8	7.8+7.8+7.8+7.8	7.8+7.8+7.8+10.0
Weight	Net Weight	kg	213+218+218+218	218+218+218+218	218+218+218+260
	Gross Weight	kg	241+246+246+246	246+246+246+246	246+246+246+291
Cabinet Color		Ivory White			
Net Dimensions	Height	mm	1730	1730	1730
	Width	mm	950+950+950+950	950+950+950+950	950+950+950+1210
	Depth	mm	750	750	750
Packing Dimensions	Height	mm	1950	1950	1950
	Width	mm	1015+1015+1015+1015	1015+1015+1015+1015	1015+1015+1015+1275
	Depth	mm	790	790	790
Ref. Piping	Gas	mm	φ41.3	φ41.3	φ41.3
		inch	1-5/8	1-5/8	1-5/8
	Liquid	mm	φ22.2	φ22.2	φ22.2
		inch	7/8	7/8	7/8
Connectable Indoor Units	Quantity	pcs	64	64	64
	Connection Ratio	-	50%~150%		
Piping Design	Max. Total Piping Length		m		1000.0
	Max. Piping Length	Actual Length	m		165.0
		Equivalent Length	m		190.0
	Height Difference Between ODU and IDU		m		When the ODU is above: 50(90°)
			m		When the ODU is below: 40(90°)
Height Difference Between IDUs		m		15(30°)	
Cooling Operating Range		°CDB	10-52		

NOTES:

- The final appearance of outdoor units is subject to the actual products.
- When the operation temperature is under 48°C DB ~ 52°C DB, please contact with our professional engineer.
- \*1: If height difference between ODU&IDU more than 50(40)m, please contact with our professional engineer.
- \*2: If the height difference between indoor units is more than 15m, please contact with our professional engineer.

# Indoor Unit

COOLING ONLY



- 4-Way Cassette Type

- Mini 4-Way Cassette Type

- 1-Way Cassette Type

- 2-Way Cassette Type

- Console Type

- Ceiling Ducted Type

- Wall Mounted Type

- Ceiling & Floor Type

- Floor Concealed Type

- All Fresh Air Indoor Unit

- Heat Recovery Ventilator

- AHU Connection Kit

COOLING ONLY

## Indoor Unit Range

HP		0.6	0.8	1.0	1.3	1.5	1.6	1.8	1.9	2.0	2.3	2.5	3.0	3.3	4.0	5.0	6.0	8.0	10.0
kBtu/h		5	7	9	12	14	15	17	18	19	22	24	27	30	38	48	54	76	96
4-Way Cassette Type				•	•		•			•	•	•	•	•	•	•	•		
Mini 4-Way Cassette Type		•	•	•	•		•	•		•									
1-Way Cassette Type			•	•	•	•			•			•							
2-Way Cassette Type			•	•	•	•			•			•	•	•	•	•	•		
Console Type		•	•	•	•		•	•											
Ceiling Ducted Type (AC Low-height)		•	•	•	•		•	•		•	•	•							
Ceiling Ducted Type (DC Low-height)		•	•	•	•		•	•		•	•	•							
Ceiling Ducted Type (High Static Pressure)			•	•	•		•			•	•	•	•	•	•	•	•	•	•
Ceiling Ducted Type (Low Static Pressure)			•	•	•		•			•	•	•	•	•	•	•	•	•	•
Wall Mounted Type		•	•	•	•		•	•				•	•						
Ceiling & Floor Type								•	•		•	•	•	•	•	•			
Floor Concealed Type				•	•				•			•							

Note: More specific capacity information, please see the introduction for each indoor unit.

## Functions & Accessories

### Installation & Maintenance



#### 1200mm condensate pump

Drain Pumps help to discharge condensate water from the indoor unit smoothly.



#### Self-Diagnosis

The self-diagnosis function in indoor units smartly determines and analyses problems occurred providing with troubleshooting hints. It is displayable and could be tracked on controller, outdoor and indoor unit itself.



#### Compact size

Compact size on indoor units offer greater installation flexibility especially in restricted space.



#### Easy cleaning

Clean effortlessly by dragging cloths across smooth flat surfaces on indoor units and prevents heavy dust accumulation.



#### Large capacity range

Indoor unit series with large capacity range offer more capacity options to closely satisfy various indoor loads.



#### Auto restart

Indoor units with Auto Restart Function, automatically restarts in default mode or restoring to the previous mode after any involuntary power cut off.



#### Low temperature cooling

Setting temperature of indoor units is widen with selectable temperature to as low as 16°C.



#### Humidity sensor (optional)

Indoor units compatible with humidity sensor accessory could access to Auto Dehumidification function on the indoor unit.



#### Hi-Motion (optional)

Hi-Motion is an human presence sensor optional accessory which enables auto airflow direction, auto ON/OFF, auto fan and setting based on human presence.

### Basic Function



#### Remote control

Control indoor units remotely using the blind spotless LCD display wireless controller



#### Quiet mode

Indoor units that offer very low sound pressure levels during operation.



#### Sleep mode

The setting temperature will be changed automatically for sweet and comfort sleep.



#### Adjustable louver's position

Louver's position of indoor units can be adjusted and fixed in different levels and angles.

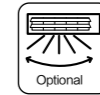

#### 3D Air-flow Panel

Selectable wind settings from normal, 3D and super long distance mode are available thanks to the 3D air-flow panel.



#### Six levels of fan speed

Six levels of fan speed are available.



#### Auto fan speed

Automatically controls rotation speed of fan depending on indoor load to achieve efficiency and comfort simultaneously.

### Air Quality



#### Fresh air Intake

Indoor units that are compatible to introduce fresh air into rooms with either an optional adapter or direct connection to the air return segment of the unit.

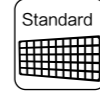

#### Standard filter included

Washable long life synthetic fibre return air filters are included with the unit.

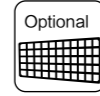

#### Optional filter

Washable long life synthetic fibre air filters does not come with indoor unit but an optional accessory.



#### AirPure (optional)

Achieving air purification by equipping with AirPure kit.



## 4-Way Cassette Type Mini 4-Way Cassette Type

### Compact and Classy Design

The 4-way cassette is now as slim as 238mm and 215mm for mini 4-way cassettes, fit for narrow ceiling spaces. Boring straight return air grille patterns are replaced with exquisite hexagon pattern design, upgrading taste and classiness of any interior aesthetic.

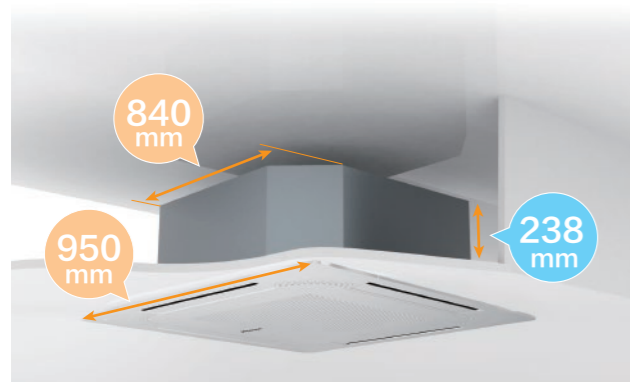

4-way Cassette Type

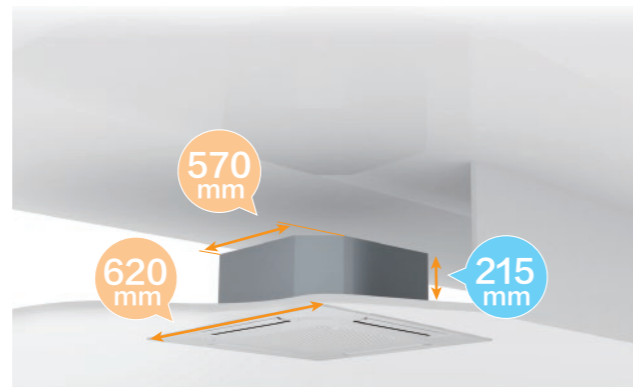

Mini 4-way Cassette Type

### Higher Installation

Air from the cassette still manages to flow down from ceiling heights as high as 4.2m. Not to mention human presence and density detection by motion sensor at such height.

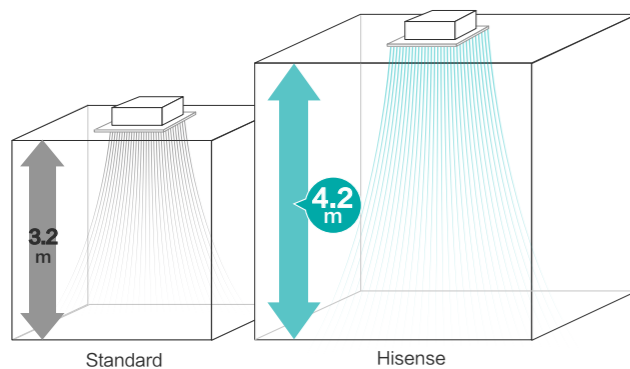

Standard

Hisense

### Breeze Mode

Under the new designed breeze mode, the cold air is blown out from the microholes in the panel, and the unit is working in a mute mode, which can avoid blowing air directly on people and achieve more even and comfortable airflow.

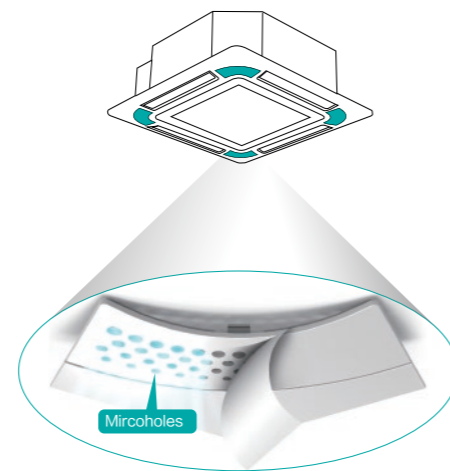

Microholes

### Individual Louver Control

4-way cassette's louvers are now capable of individual control to freely choose how you want your AC unit supplies air according to different needs, applications and installation layout. Each louvers have 7 angle settings with angle range from 28° to 52°.

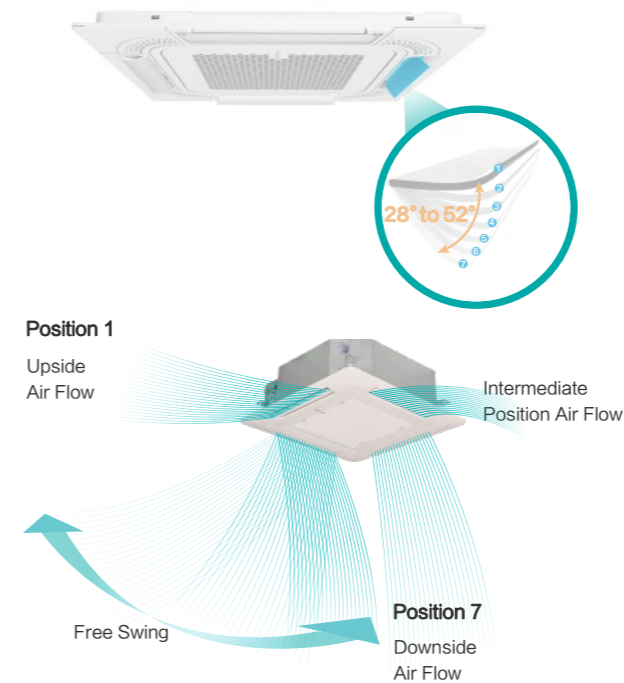

### Fresh Air Intake (Optional)

In order to satisfy the fresh air intake function, the duct adapter as the optional part equips at the mini 4-way cassette type and 4-way cassette type.

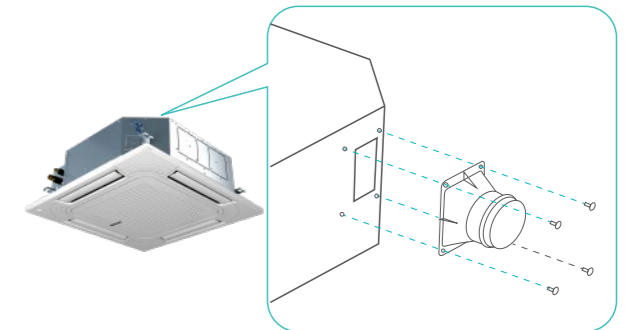

### Humidity Sensor(optional)

Automatic dehumidification can be achieved by choosing humidity sensor, setting humidity range from 35% to 90%.

### Motion Sensor

The sensor senses the presence of people to automatically turn the cassette unit on or off and whether to direct airflow towards or avoiding humans depend settings set on the controller. During crowded times, the setting temperature is automatically lowered down and vice versa. Meeting comfort and using energy only when necessary.

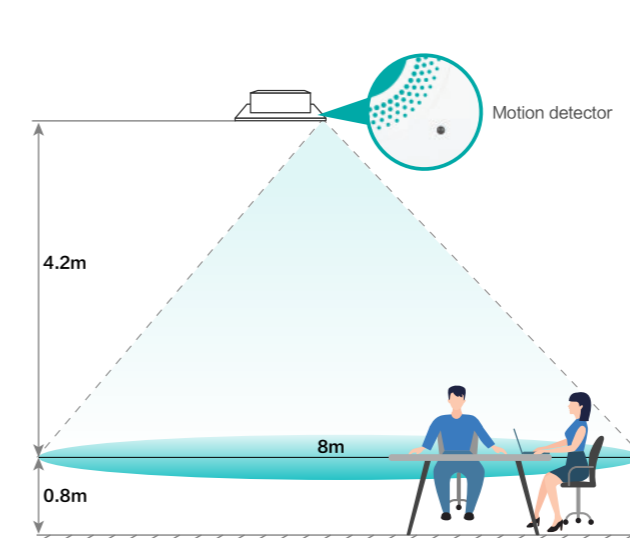

Motion detector

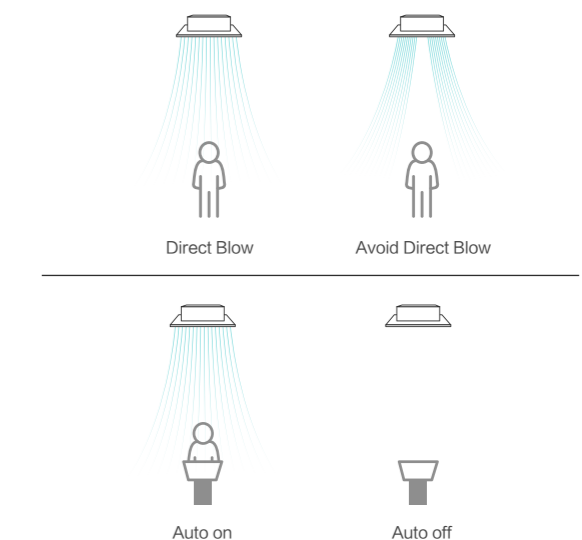

### 4-Way Cassette Type



### Mini 4-Way Cassette Type



Model			AVBC-09 HJFKA	AVBC-12 HJFKA	AVBC-15 HJFKA	AVBC-19 HJFKA	AVBC-22 HJFKA	AVBC-24 HJFKA	AVBC-27 HJFKA	AVBC-30 HJFKA	AVBC-38 HJFKA	AVBC-48 HJFKA	AVBC-54 HJFKA
Power Supply			AC 1ϕ, 220~240V/50Hz/60Hz										
Capacity	Cooling	kW	2.8	3.6	4.5	5.6	6.3	7.1	8.0	9.0	11.2	14.0	16.0
		Btu/h	9,600	12,300	15,400	19,100	21,500	24,200	27,300	30,700	38,200	47,800	54,600
Power Input	Cooling	W	14	24	24	34	54	64	54	54	124	124	124
Sound Pressure	dB(A)		30/28/28/ 27/26/26	32/29/29/ 28/27/26	33/31/29/ 29/27/26	34/31/30/ 28/28/26	36/33/32/ 31/29/28	36/33/32/ 31/29/28	37/36/35/ 33/31/30	37/36/35/ 33/31/30	42/40/38/ 36/34/33	46/44/40/ 38/36/34	46/44/41/ 40/38/36
			15.0/13.4/ 12.0/10.8/ 10.0/8.8	17.0/14.0/ 12.8/11.8/ 10.8/9.1	21.0/16.0/ 14.9/13.6/ 12.7/11.2	22.0/17.5/ 15.9/15.5/ 13.6/12.5	26.0/20.0/ 18.3/17.0/ 15.1/13.0	27.0/21.0/ 19.1/18.0/ 16.3/14.7	27.0/22.0/ 20.3/18.7/ 16.8/15.4	27.0/23.0/ 20.7/19.6/ 17.7/16.1	37.0/30.0/ 27.4/24.8/ 22.4/19.6	37.0/33.5/ 29.6/27.2/ 24.5/22.4	37.0/34.0/ 30.7/28.9/ 25.6/23.8
Air Flow Rate	m³/min		12.0/10.8/ 10.0/8.8	12.8/11.8/ 10.8/9.1	14.9/13.6/ 12.7/11.2	15.9/15.5/ 13.6/12.5	18.3/17.0/ 15.1/13.0	19.1/18.0/ 16.3/14.7	20.3/18.7/ 16.8/15.4	20.7/19.6/ 17.7/16.1	27.4/24.8/ 22.4/19.6	29.6/27.2/ 24.5/22.4	30.7/28.9/ 25.6/23.8
Piping	Connection Type	-	Flare-nut Connection(with Flare Nuts)										
	Liquid	mm	ϕ6.35	ϕ6.35	ϕ6.35	ϕ6.35	ϕ6.35	ϕ9.53	ϕ9.53	ϕ9.53	ϕ9.53	ϕ9.53	ϕ9.53
		inch	1/4	1/4	1/4	1/4	1/4	3/8	3/8	3/8	3/8	3/8	3/8
	Gas	mm	ϕ12.7	ϕ12.7	ϕ12.7	ϕ12.7	ϕ12.7	ϕ15.88	ϕ15.88	ϕ15.88	ϕ15.88	ϕ15.88	ϕ15.88
		inch	1/2	1/2	1/2	1/2	1/2	5/8	5/8	5/8	5/8	5/8	5/8
Condensate Drain	mm	O.D. 32											
Weight	Net Weight	kg	20	20	21	21	23	23	26	26	26	26	26
	Gross Weight	kg	24	24	25	25	27	27	31	31	31	31	31
Dimensions	External	H mm	238	238	238	238	238	238	288	288	288	288	288
		W mm	840	840	840	840	840	840	840	840	840	840	840
		D mm	840	840	840	840	840	840	840	840	840	840	840
	Packaging	H mm	292	292	292	292	292	292	342	342	342	342	342
		W mm	945	945	945	945	945	945	945	945	945	945	945
		D mm	945	945	945	945	945	945	945	945	945	945	945
Model	-	HP-G-NK	HP-G-NK	HP-G-NK	HP-G-NK	HP-G-NK	HP-G-NK	HP-G-NK	HP-G-NK	HP-G-NK	HP-G-NK	HP-G-NK	
Panel Colour	-	Neutral White											
Decoration Panel	Body Dimensions	H mm	47	47	47	47	47	47	47	47	47	47	47
		W mm	950	950	950	950	950	950	950	950	950	950	950
		D mm	950	950	950	950	950	950	950	950	950	950	950
	Packaging Dimensions	H mm	105	105	105	105	105	105	105	105	105	105	105
		W mm	1014	1014	1014	1014	1014	1014	1014	1014	1014	1014	1014
		D mm	1014	1014	1014	1014	1014	1014	1014	1014	1014	1014	1014
	Net Weight	kg	5.7	5.7	5.7	5.7	5.7	5.7	5.7	5.7	5.7	5.7	5.7
Gross Weight	kg	8	8	8	8	8	8	8	8	8	8	8	

NOTES:

1. The nominal cooling capacity is based on following conditions:  
Indoor Air Inlet Temperature:27°C DB(80°F DB), 19.0°C WB(66.2°F WB)  
Outdoor Air Inlet Temperature:35°C DB(95°F DB)  
Piping Length:7.5 Meters Piping Lift:0 Meter

2. The sound pressure level is based on following conditions:1.5m beneath the unit.  
The above data was measured in an anechoic chamber so that reflected sound should be taken into consideration in the field.

Model			AVC-05HJFA	AVC-07HJFA	AVC-09HJFA	AVC-12HJFA	AVC-15HJFA	AVC-17HJFA	AVC-19HJFA
Power Supply			AC 1ϕ, 220~240V/50Hz/60Hz						
Capacity	Cooling	kW	1.5	2.2	2.8	3.6	4.5	5.0	5.6
		Btu/h	5,100	7,480	9,520	12,240	15,300	17,000	19,040
Power Input	Cooling	W	14	14	14	16	22	30	40
Sound Pressure		dB(A)	30/29/28/26	30/29/28/26	32/30/28/26	34/32/29/26	38/36/31/28	42/39/36/31	45/42/38/34
Air Flow Rate		m³/min	7.2/6.5/6.2/5.6	7.2/6.5/6.2/5.6	7.8/7.2/6.5/5.8	8.2/7.2/6.5/5.8	9.3/8.7/7.1/6.7	11.0/9.5/8.7/7.1	12.5/10.8/9.3/8.0
Piping	Connection Type	-	Flare-nut Connection(with Flare Nuts)						
	Liquid	mm	ϕ6.35	ϕ6.35	ϕ6.35	ϕ6.35	ϕ6.35	ϕ6.35	ϕ6.35
		inch	1/4	1/4	1/4	1/4	1/4	1/4	1/4
	Gas	mm	ϕ12.7	ϕ12.7	ϕ12.7	ϕ12.7	ϕ12.7	ϕ12.7	ϕ12.7
		inch	1/2	1/2	1/2	1/2	1/2	1/2	1/2
Condensate Drain	mm	O.D. 32							
Weight	Net Weight	kg	14.5	14.5	14.8	14.8	15.8	15.8	15.8
	Gross Weight	kg	17.3	17.3	17.6	17.6	18.6	18.6	18.6
Dimensions	External	H mm	215	215	215	215	215	215	215
		W mm	570	570	570	570	570	570	570
		D mm	570	570	570	570	570	570	570
	Packaging	H mm	292	292	292	292	292	292	292
		W mm	668	668	668	668	668	668	668
		D mm	730	730	730	730	730	730	730
Model	-	HPE-D-NK	HPE-D-NK	HPE-D-NK	HPE-D-NK	HPE-D-NK	HPE-D-NK	HPE-D-NK	
Panel Colour	-	Neutral White							
Decoration Panel	Body Dimensions	H mm	37	37	37	37	37	37	37
		W mm	620	620	620	620	620	620	620
		D mm	620	620	620	620	620	620	620
	Packaging Dimensions	H mm	115	115	115	115	115	115	115
		W mm	680	680	680	680	680	680	680
		D mm	690	690	690	690	690	690	690
Net Weight	kg	2.7	2.7	2.7	2.7	2.7	2.7	2.7	
Gross Weight	kg	4.5	4.5	4.5	4.5	4.5	4.5	4.5	

NOTES:

1. The nominal cooling capacity is based on following conditions:  
Indoor Air Inlet Temperature:27°C DB(80°F DB), 19.0°C WB(66.2°F WB)  
Outdoor Air Inlet Temperature:35°C DB(95°F DB)  
Piping Length:7.5 Meters Piping Lift:0 Meter

2. The sound pressure level is based on following conditions:1.5m beneath the unit.  
The above data was measured in an anechoic chamber so that reflected sound should be taken into consideration in the field.

# 1-Way Cassette Type

## Chic Aesthetics

Inspired from ceiling concealed ducted units and integrated with the design of cassette units to present 1 way cassette. High class appearance blends into common white plaster ceilings and practical solution for cornered floor layouts, hotel rooms and residential applications.



## Space Saving

Slim body height of 192mm fits in limited ceiling spaces commonly seen in budget hotels and residential applications.

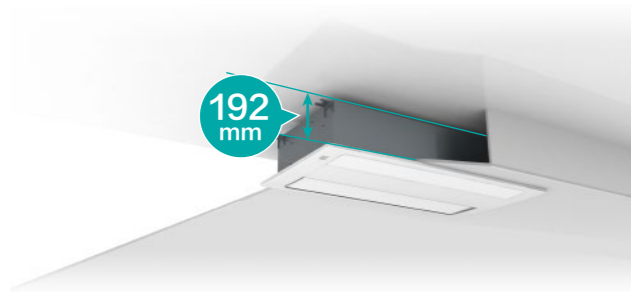

## Wide Angle of Air Supply

Louvers are consist of horizontal and vertical flaps. They can supply air evenly to the edges of the room with wider discharge angle from 17° to 65°.

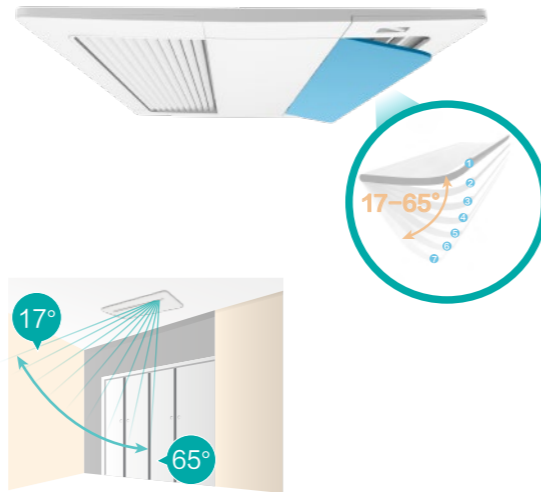

## Easier Maintain

The electric box of the cassette is designed and placed beneath the panel. When operate on PCB, it just needs to open the panel and the cover of box. It's easy to take the service, maintenance and commissioning.



## 1-Way Cassette Type

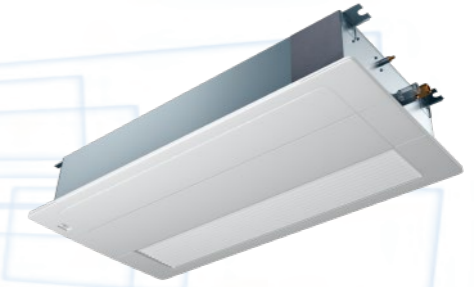
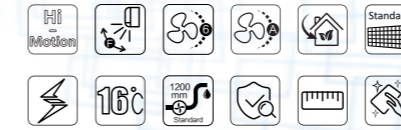

Model			AVY-07UXJSJA	AVY-09UXJSJA	AVY-12UXJSJA	AVY-14UXJSJA	AVY-18UXJSKA	AVY-24UXJSJA
Power Supply			AC 1Φ, 220-240V/50Hz/60Hz					
Capacity	Cooling	kW	2.2	2.8	3.6	4.0	5.6	7.1
		Btu/h	7,500	9,600	12,300	13,600	19,100	24,200
Power Input	Cooling	W	14	14	24	34	34	74
		Sound Pressure	dB(A)	33/32/31/30/29/28	35/34/32/31/29/28	40/36/35/33/30/29	40/36/35/33/30/29	41/39/36/35/33/31
Air Flow Rate	m³/min		6.2/5.9/5.6/	6.6/6.2/5.6/	8.3/7.3/6.8/	8.3/7.3/6.8/	12.1/9.9/8.8/	15.6/12.6/11.2/
			5.1/4.8/4.6	5.1/4.8/4.6	6.2/5.6/5.1	6.2/5.6/5.1	8.2/7.8/6.6	9.9/8.4/7.1
Piping	Connection Type		Flare-nut Connection(with Flare Nuts)					
	Liquid	mm	Φ6.35	Φ6.35	Φ6.35	Φ6.35	Φ6.35	Φ9.53
		inch	1/4	1/4	1/4	1/4	1/4	3/8
	Gas	mm	Φ12.7	Φ12.7	Φ12.7	Φ12.7	Φ15.88	Φ15.88
inch		1/2	1/2	1/2	1/2	5/8	5/8	
Condensate Drain	mm	I.D. 32						
Weight	Net Weight	kg	19	19	20	20	24	24
	Gross Weight	kg	23	23	24	24	29	29
Dimensions	External	H mm	192	192	192	192	192	192
		W mm	910	910	910	910	1180	1180
		D mm	470	470	470	470	470	470
	Packaging	H mm	268	268	268	268	268	268
		W mm	1136	1136	1136	1136	1406	1406
		D mm	574	574	574	574	574	574
Decoration Panel	Model		HP-D-NA	HP-D-NA	HP-D-NA	HP-D-NA	HP-E-NA	HP-E-NA
	Panel Colour		Neutral White					
	Body Dimensions	H mm	55	55	55	55	55	55
		W mm	1100	1100	1100	1100	1370	1370
		D mm	550	550	550	550	550	550
	Packaging Dimensions	H mm	130	130	130	130	130	130
		W mm	1160	1160	1160	1160	1430	1430
		D mm	610	610	610	610	610	610
Net Weight	kg	5	5	5	5	6	6	
Gross Weight	kg	8	8	8	8	10	10	

NOTES:

1. The nominal cooling capacity is based on the following conditions:  
 Indoor Air Inlet Temperature: 27°C DB (80°F DB), 19.0°C WB(66.2°F WB)  
 Outdoor Air Inlet Temperature: 35°C DB(95°F DB)  
 Piping Length: 7.5 Meters Piping Lift: 0 Meter

2. The sound pressure level is based on the following conditions:1.0m beneath the unit,1.0m from Discharge Grille. The above data was measured in an anechoic chamber so that the reflected sound should be taken into consideration in the field. When bottom air inlet is adopted, the sound pressure will increase according to factors such as installation mode and the room structure.

## 2-Way Cassette Type

### Compact and Classy Design

The slim structure of the cassette having height as low as 298mm can be installed in ceiling spaces with a minimum of 310mm. Narrow corridors or zoned spaces are best fitted with 2-way cassette thanks to its compact design.

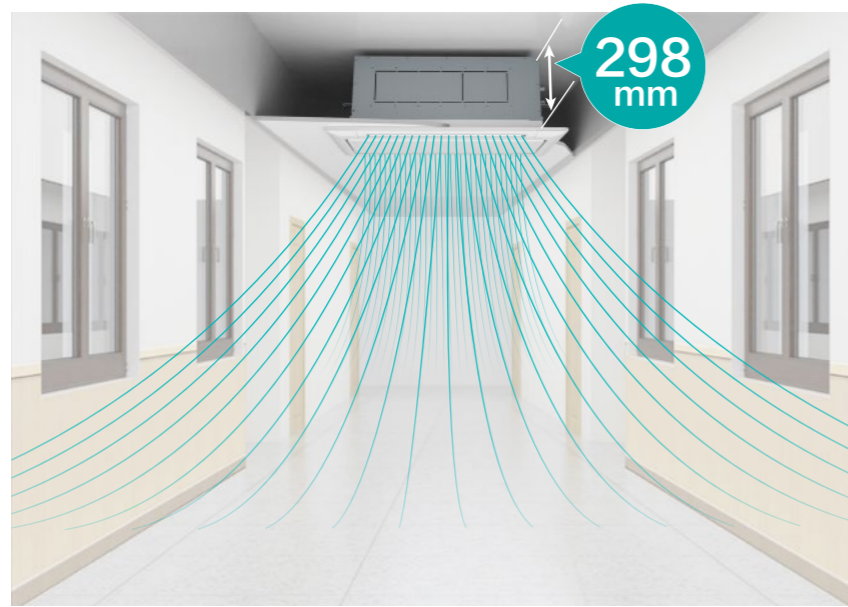

### Individual Louver Control

Each louver's opening angles are controllable individually with a total of 8 choices, with opening angle from 27° to 84° to cover high ceiling narrow long corridors needs.

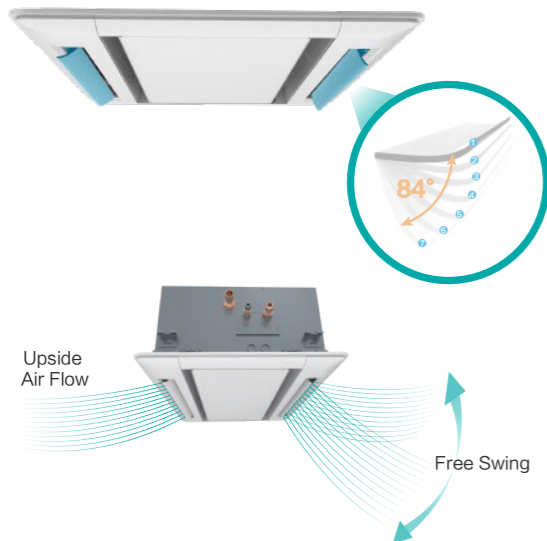

### Branch Discharge Option

In irregular room layouts, branch discharge could come in handy by extending air distribution area to the most awkward corners without additional indoor units.

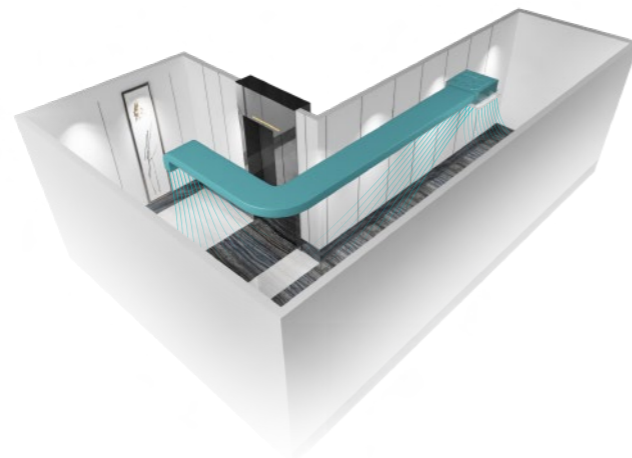

## 2-Way Cassette Type

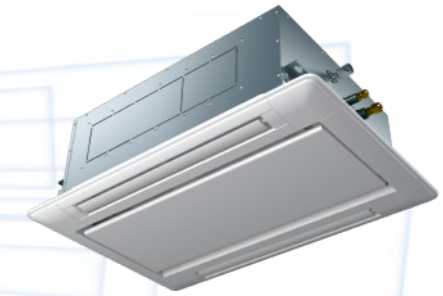

Model		AVL-07 UXJSGA	AVL-09 UXJSGA	AVL-12 UXJSGA	AVL-14 UXJSGA	AVL-18 UXJSGA	AVL-24 UXJSGA	AVL-27 UXJSGA	AVL-30 UXJSGA	AVL-38 UXJSHA	AVL-48 UXJSHA	AVL-54 UXJSHA	
Power Supply		AC 1Φ, 220-240V/50Hz/60Hz											
Capacity	Cooling	kW	2.2	2.8	3.6	4.3	5.6	7.1	8.4	9.0	11.2	14.0	16.0
		Btu/h	7,500	9,600	12,300	14,700	19,100	24,200	28,700	30,700	38,200	47,800	54,600
Power Input	Cooling	W	14	14	14	24	34	44	64	74	84	104	114
Sound Pressure	dB(A)		32/30/ 29/27	33/30/ 29/28	34/31/ 30/28	40/37/ 34/32	42/39/ 36/33	45/42/ 40/36	47/44/ 40/36	49/46/ 42/37	46/44/ 40/38	48/45/ 42/38	49/46/ 43/40
		Air Flow Rate	m <sup>3</sup> /min	10.0/8.5/ 7.2/6.0	11.0/9.4/ 8.2/6.6	12.0/10.5/ 8.9/7.5	15.0/13.2/ 11.5/9.9	17.0/14.9/ 13.0/11.2	19.0/16.4/ 14.3/12.3	21.0/18.4/ 15.6/12.6	22.0/19.3/ 16.3/13.1	30.0/26.4/ 23.1/19.8	35.0/30.8/ 26.9/21.1
Connection Type		Flare-nut Connection(with Flare Nuts)											
Piping	Liquid	mm	φ6.35	φ6.35	φ6.35	φ6.35	φ6.35	φ9.53	φ9.53	φ9.53	φ9.53	φ9.53	φ9.53
		inch	1/4	1/4	1/4	1/4	1/4	3/8	3/8	3/8	3/8	3/8	3/8
	Gas	mm	φ12.7	φ12.7	φ12.7	φ12.7	φ12.7	φ15.88	φ15.88	φ15.88	φ15.88	φ15.88	φ15.88
		inch	1/2	1/2	1/2	1/2	1/2	5/8	5/8	5/8	5/8	5/8	5/8
Condensate Drain		mm	I.D. 32										
Weight	Net Weight	kg	22	22	22	24	24	24	24	24	39	39	39
	Gross Weight	kg	28	28	28	30	30	30	30	30	47	47	47
Dimensions	External	H mm	298	298	298	298	298	298	298	298	298	298	298
		W mm	860	860	860	860	860	860	860	860	1420	1420	1420
		D mm	630	630	630	630	630	630	630	630	630	630	630
	Packaging	H mm	350	350	350	350	350	350	350	350	350	350	350
		W mm	1070	1070	1070	1070	1070	1070	1070	1070	1630	1630	1630
		D mm	710	710	710	710	710	710	710	710	710	710	710
Decoration Panel	Model	-	HP-C-NA	HP-C-NA	HP-C-NA	HP-C-NA	HP-C-NA	HP-C-NA	HP-C-NA	HP-C-NA	HP-F-NA	HP-F-NA	
	Panel Colour	-	Neutral White										
	Body Dimensions	H mm	30	30	30	30	30	30	30	30	30	30	30
		W mm	1100	1100	1100	1100	1100	1100	1100	1100	1100	1660	1660
		D mm	710	710	710	710	710	710	710	710	710	710	710
	Packaging Dimensions	H mm	160	160	160	160	160	160	160	160	160	160	160
W mm		1170	1170	1170	1170	1170	1170	1170	1170	1170	1710	1710	
D mm		740	740	740	740	740	740	740	740	740	740	740	
Net Weight	kg	7.5	7.5	7.5	7.5	7.5	7.5	7.5	7.5	10.5	10.5	10.5	
Gross Weight	kg	13.3	13.3	13.3	13.3	13.3	13.3	13.3	13.3	17.8	17.8	17.8	

NOTES:

1. The nominal cooling capacity is based on the following conditions:  
 Indoor Air Inlet Temperature: 27°C DB (80°F DB), 19.0°C WB(66.2°F WB)  
 Outdoor Air Inlet Temperature: 35°C DB(95°F DB)  
 Piping Length: 7.5 Meters Piping Lift: 0 Meter

2. The sound pressure level is based on the following conditions: 1.5m beneath the unit.  
 The above data was measured in an anechoic chamber so that the reflected sound should be taken into consideration in the field.

## Console Type

### Stylish Aesthetics

Smooth white matte cover with LED power and temperature display console unit is an upgraded stylish air-conditioning option to the ordinaries. Suitable for any residential or commercial applications needed an AC unit near the floor for effective heating during the winter and cooling during summer.

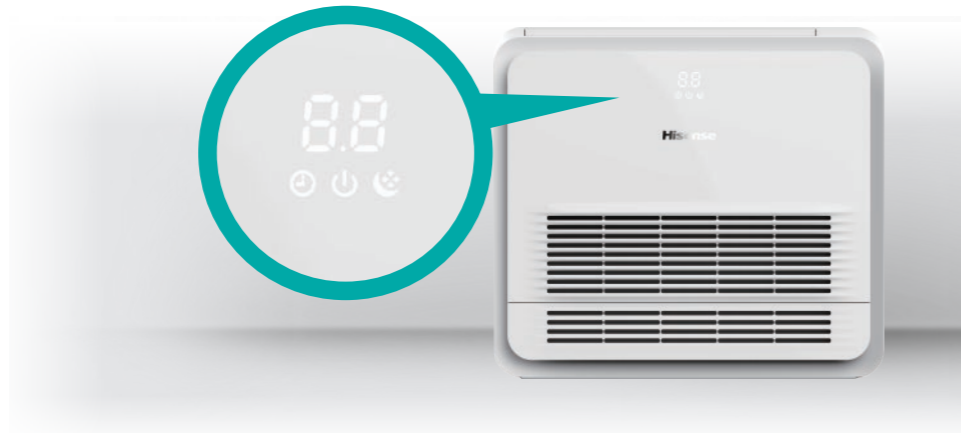

### Assorted Modes

#### Cooling Mode

The unit adopts the stereo cooling mode that can reach the setting temperature rapidly.

NOTE:  
If indoor unit has been running in low fan speed mode for an hour, the air louver below will close automatically.

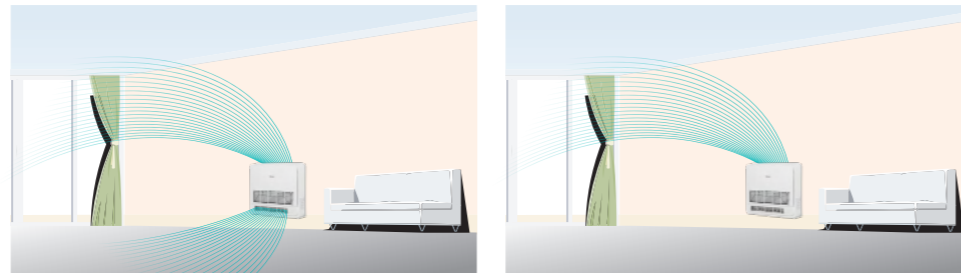

### Flexible Installation Options

Despite of the suitability of floor installment for console units, it is still available for wall mounting too. For a sleek look, the unit could also be installed semi-concealed or totally concealed to be used as concealed floor units.

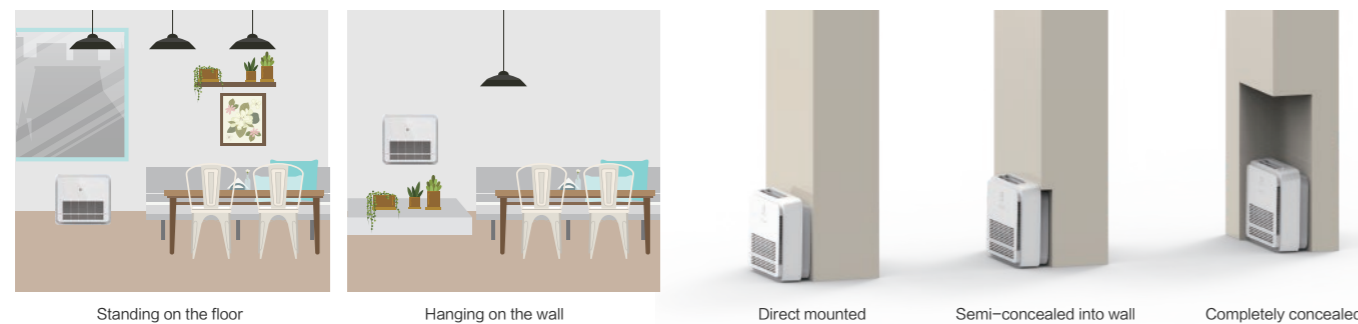

### Flexible Piping Connection

Both refrigerant and drainage pipings are freely to connect in any direction including any sides. An additional direction to the back of the unit for refrigerant pipes to allow passing through walls.

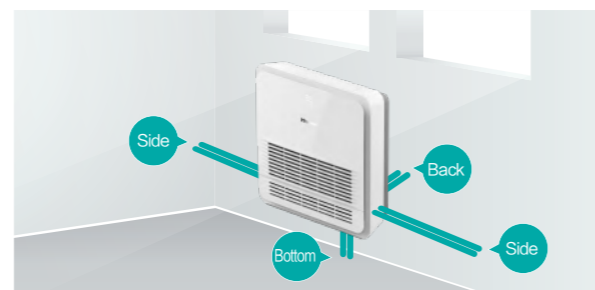

## Console Type



Model		AVK-05HJFCAA	AVK-07HJFCAA	AVK-09HJFCAA	AVK-12HJFCAA	AVK-15HJFCAA	AVK-17HJFCAA	
Power Supply		AC 1ϕ, 220V~240V/50Hz/60Hz						
Capacity	Cooling	kW	1.5	2.2	2.8	3.6	4.5	5.0
		Btu/h	5,100	7,500	9,600	12,300	15,300	17,000
Power Input	Cooling	W	10	11	12	14	18	23
Sound Pressure		dB(A)	32/30/29/28/26/24	34/32/31/29/27/26	36/35/32/31/29/27	39/36/34/31/29/27	41/39/37/35/33/32	44/43/41/39/37/36
Air Flow Rate		m <sup>3</sup> /min	6.0/5.7/5.3/ 5.1/4.7/4.5	7.4/7.0/6.4/ 6.0/5.6/5.3	8.0/7.4/7.0/ 6.4/6.0/5.6	8.2/7.6/6.8/ 6.2/5.7/5.3	9.0/8.5/7.8/ 7.2/6.6/6.4	10.1/9.7/9.0/ 8.5/7.9/7.3
		Panel Colour	-	Pure White	Pure White	Pure White	Pure White	Pure White
Piping	Connection Type	-	Flare-nut Connection(with Flare Nuts)					
	Liquid	mm	ϕ 6.35	ϕ 6.35	ϕ 6.35	ϕ 6.35	ϕ 6.35	ϕ 6.35
		inch	1/4	1/4	1/4	1/4	1/4	1/4
	Gas	mm	ϕ 12.7	ϕ 12.7	ϕ 12.7	ϕ 12.7	ϕ 12.7	ϕ 12.7
inch		1/2	1/2	1/2	1/2	1/2	1/2	
Condensate Drain	mm	O.D. 18						
Weight	Net Weight	kg	16.1	16.1	16.1	17.4	17.4	17.4
	Gross Weight	kg	20.6	21.1	21.1	21.5	21.5	21.5
Dimensions	External	H mm	630	630	630	630	630	630
		W mm	700	700	700	700	700	700
		D mm	225	225	225	225	225	225
	Packaging	H mm	725	725	725	725	725	725
		W mm	790	790	790	790	790	790
		D mm	315	315	315	315	315	315

#### NOTES:

1. The nominal cooling capacity is based on the following conditions:  
Indoor Air Inlet Temperature: 27°C DB(80°F DB), 19.0°C WB(66.2°F WB)  
Outdoor Air Inlet Temperature: 35°C DB(95°F DB)  
Piping Length: 7.5 Meters Piping Lift: 0 Meter

2. The sound pressure level is based on following conditions:  
It is measured in anechoic room. Operation noise differs with operation and ambient conditions.  
Location of Microphone:

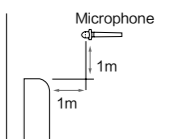

## Ceiling Ducted Type (AC/DC Low Height, High/Low Static Pressure)

### Space Saving

Concealed AC/DC Low Height Ducted unit is as slim as 192mm, fitting into the narrowest ceiling spaces. Save ceiling spaces for higher room height without compromising user's comfort and satisfaction.



### Flexible Air Supply and Return

Available air return as rear or bottom entry, consumers can choose relevant air return mode according to the practical installation space.

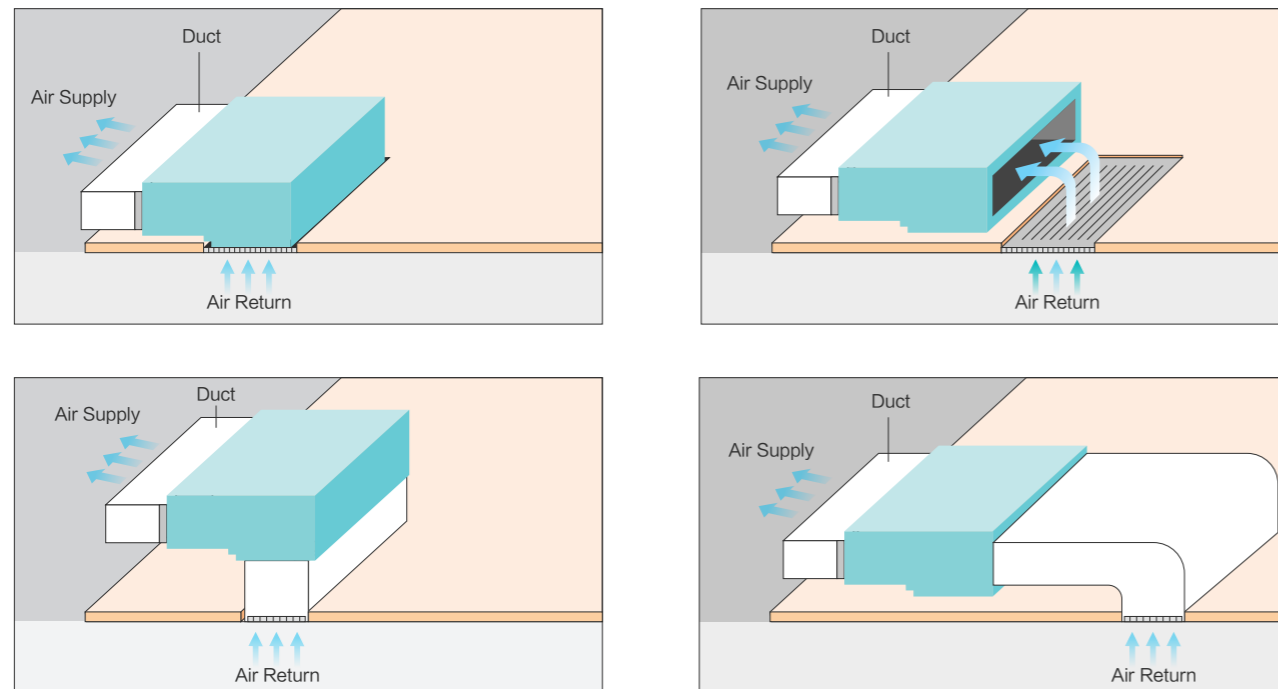

### 3D Air Flow

Classy air discharge louver panel with LED temperature and humidity display is available as an optional accessory for the AC/DC Low Height Ducted Units. The 3D louvers on the panel offer wide air flow coverage to keep every corners of your room cool or warm in any seasons of the year.

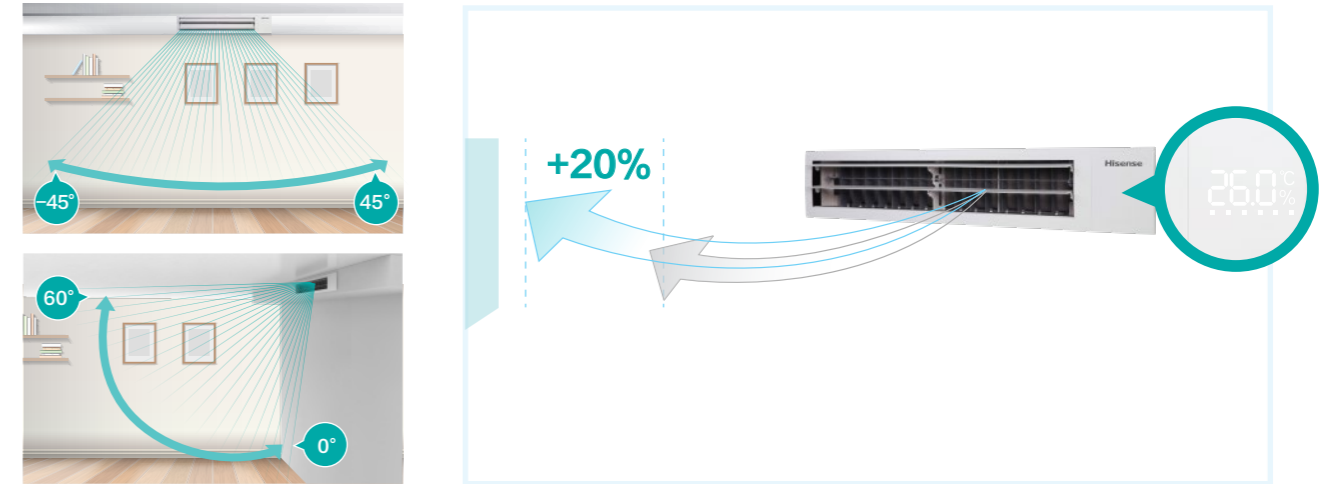

### Adjustable Static Pressure\*

Static pressures in free supply applications would create unnecessary air-blowing noises. Hence, the fan's static pressure is made adjustable to suit different applications more precisely with smaller adjustment steps.

\*: AC/DC Low Height, Low Static and High Static Pressure Ducted Unit have different number of static pressure choices, please refer to the specifications for more detailed information.

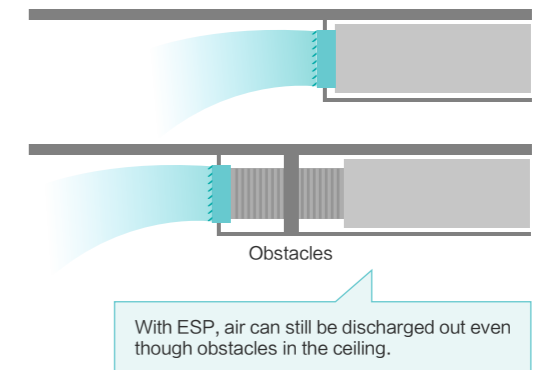

With ESP, air can still be discharged out even though obstacles in the ceiling.

### Various Device Connection Options

Third party devices and sensors are available to control the on/off of air conditioner via dry contact connection. Devices like hotel room key card, window contact and fire alarm can also be connected simultaneously.

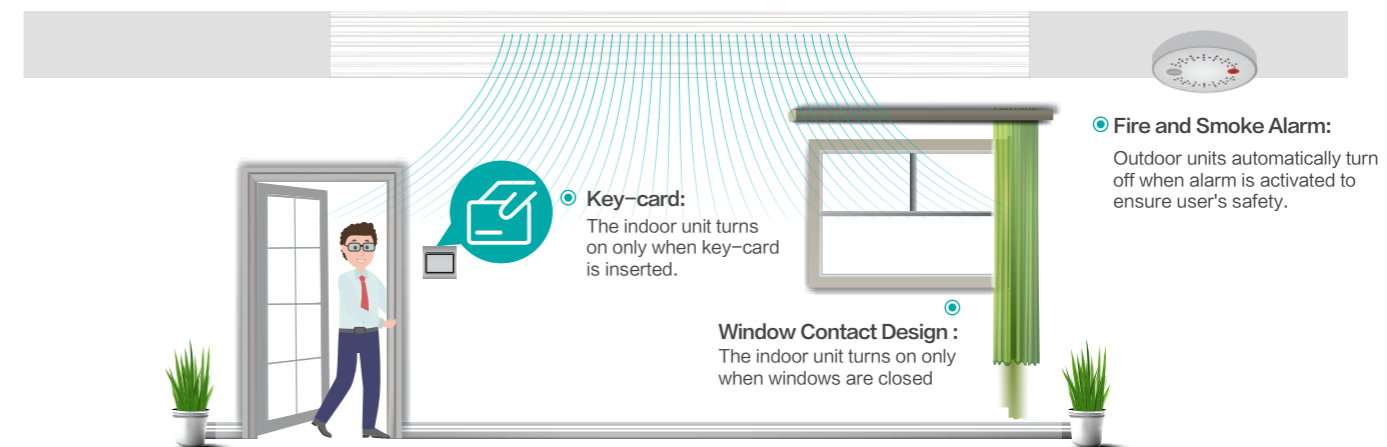



### Ceiling Ducted Type (High Static Pressure)

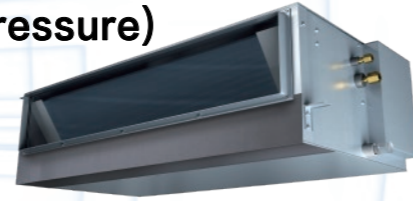
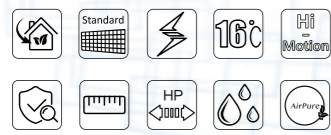

### Ceiling Ducted Type (Low Static Pressure)

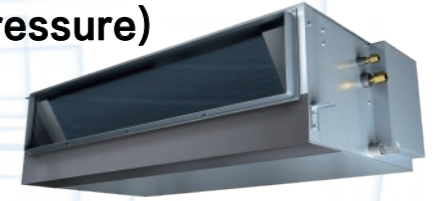
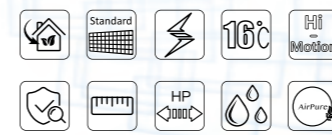

Model	AVD-07 HCFCH	AVD-09 HCFCH	AVD-12 HCFCH	AVD-15 HCFCH	AVD-19 HCFCH	AVD-22 HCFCH	AVD-24 HCFCH	AVD-27 HCFCH	AVD-30 HCFCH	AVD-38 HCFCH	AVD-48 HCFCH	AVD-54 HCFCH	AVD-76UX-6SEH	AVD-96U X6SFH			
Power Supply	AC 1 φ, 220V~240V/50Hz												AC 3 φ, 380-415V/50Hz				
Model	AVD-07 H3FCH	AVD-09 H3FCH	AVD-12 H3FCH	AVD-15 H3FCH	AVD-19 H3FCH	AVD-22 H3FCH	AVD-24 H3FCH	AVD-27 H3FCH	AVD-30 H3FCH	AVD-38 H3FCH	AVD-48 H3FCH	AVD-54 H3FCH	—	—			
Power Supply	AC 1 φ, 208~230V/60Hz																
Capacity	Cooling	kW	2.2	2.8	3.6	4.5	5.6	6.3	7.1	8.0	9.0	11.2	14.0	16.0	22.4	28.0	
		Btu/h	7500	9600	12300	15400	19100	21600	24200	27400	30800	38000	48000	54500	76500	95600	
Power Input	Cooling	kW	0.10(0.13*)	0.10(0.13*)	0.13(0.16*)	0.13(0.16*)	0.14(0.21*)	0.19(0.24*)	0.19(0.24*)	0.25(0.34*)	0.25(0.34*)	0.34(0.45*)	0.43(0.59*)	1.03	1.28		
Sound Pressure	220~240V/50Hz	dB(A)	32/27/25	32/27/25	35/32/26	35/32/26	36/35/30	39/32/25	39/32/25	42/39/34	42/39/34	42/39/34	43/40/35	46/40/35	52	54	
	208V/60Hz	dB(A)	33/28/24	33/28/24	37/34/29	37/34/29	37/35/29	39/32/25	39/32/25	42/38/33	42/38/33	42/38/33	44/39/34	45/40/34	52	54	
	230V/60Hz	dB(A)	37/33/28	37/33/28	40/38/33	40/38/33	42/40/34	43/37/30	43/37/30	44/42/37	44/42/37	44/42/37	47/43/38	46/42/38	52	54	
Air Flow(Hi/Me/Lo)		m <sup>3</sup> /min	9/7/6	9/7/6	12/10/8.5	12/10/8.5	15/13/10	19/14/10	19/14/10	28/24/19.5	28/24/19.5	28/24/19.5	35.5/29/24	39/31/24	58	77.5	
External Static Pressure	220~240V/50Hz	Pa	50(80)	50(80)	50(80)	50(80)	50(80)	50(80)	50(80)	120(90)	120(90)	120(90)	120(90)	120(90)	220	220	
	230V/60Hz	Pa	80(105)	80(105)	90(115)	90(115)	90(115)	90(115)	90(115)	170(150)	170(150)	170(150)	170(150)	170(150)	—	—	
Piping	Connection Type	—	Flare-nut Connection(with Flare Nuts)												Brazing		
	Liquid	mm	φ6.35	φ6.35	φ6.35	φ6.35	φ6.35	φ9.53	φ9.53	φ9.53	φ9.53	φ9.53	φ9.53	φ9.53	φ9.53	φ9.53	φ9.53
		inch	1/4	1/4	1/4	1/4	1/4	3/8	3/8	3/8	3/8	3/8	3/8	3/8	3/8	3/8	3/8
	Gas	mm	φ12.7	φ12.7	φ12.7	φ12.7	φ15.88	φ15.88	φ15.88	φ15.88	φ15.88	φ15.88	φ15.88	φ15.88	φ19.05	φ22.2	
		inch	1/2	1/2	1/2	1/2	5/8	5/8	5/8	5/8	5/8	5/8	5/8	5/8	3/4	7/8	
Condensate Drain	mm	I.D. 32															
Weight	Net Weight	kg	25(24*)	25(24*)	25(24*)	25(24*)	30(31*)	30(31*)	30(31*)	45(44*)	45(44*)	45(44*)	53(50*)	53(50*)	94	106	
	Gross Weight	kg	29(30*)	29(30*)	31(30*)	31(30*)	36(38*)	37(38*)	37(38*)	52(52*)	52(52*)	52(52*)	61(59*)	61(59*)	112	123	
Dimensions	External	H mm	270	270	270	270	270	270	300	300	300	300	300	300	470	470	
		W mm	650+75	650+75	650+75	650+75	900+75	900+75	900+75	1100+75	1100+75	1100+75	1400+75	1400+75	1060	1250	
		D mm	720	720	720	720	720	720	720	800	800	800	800	800	800	1120	1120
	Packaging	H mm	385	385	385	385	385	385	385	415	415	415	415	415	546	546	
		W mm	895	895	895	895	1140	1140	1140	1345	1345	1345	1640	1640	1276	1466	
		D mm	870	870	870	870	870	870	870	950	950	950	950	950	950	1345	1345

Notes:

1. The nominal cooling capacity and heating capacity are based on the following conditions:  
 Cooling Operation Conditions  
 Indoor Air Inlet Temperature: 27°C DB(80°F DB), 19.0°C WB(66.2°F WB)  
 Outdoor Air Inlet Temperature: 35°C DB(95°F DB)  
 Piping Length: 7.5 Meters Piping Lift: 0 Meter  
 Heating Operation Conditions  
 Indoor Air Inlet Temperature: 20°C DB(68°F DB)  
 Outdoor Air Inlet Temperature: 7°C DB(45°F DB), 6°C WB(43°F WB)

2. The sound pressure level is based on the following conditions: 1.5m beneath the unit.  
 With discharge duct (2.0m) and return duct(1.0m)  
 The above data was measured in an anechoic chamber so that the reflected sound should be taken into consideration in the field.

3. When bottom air inlet is adopted, the sound pressure will increase according to factors such as installation mode and the room structure.

\*: The value noted \* is the parameter of the indoor units with power supply 208~230V/60Hz.

Model	AVD-07 HCFCL	AVD-09 HCFCL	AVD-12 HCFCL	AVD-15 HCFCL	AVD-19 HCFCL	AVD-22 HCFCL	AVD-24 HCFCL	AVD-27 HCFCL	AVD-30 HCFCL	AVD-38 HCFCL	AVD-48 HCFCL	AVD-54 HCFCL	AVD-76U X6SEL	AVD-96U X6SFL		
Power Supply	AC 1 φ, 220V~240V/50Hz												AC 3 φ, 380-415V/50Hz			
Capacity	Cooling	kW	2.2	2.8	3.6	4.5	5.6	6.3	7.1	8.0	9.0	11.2	14.0	16.0	22.4	28.0
		Btu/h	7,500	9,600	12,300	15,400	19,100	21,600	24,200	27,400	30,800	38,000	48,000	54,500	76,500	95,600
Power Input	Cooling	W	60	60	110	110	90	160	160	240	240	240	290	360	950	1120
Sound Pressure		dB(A)	27/23/21	27/23/21	34/30/25	34/30/25	32/30/26	35/28/24	35/28/24	38/33/30	38/33/30	38/33/30	41/38/33	44/39/33	50	52
Air Flow Rate (Hi/Me/Lo)		m <sup>3</sup> /min	9/7/6	9/7/6	12/10/8.5	12/10/8.5	15/13/10	19/14/10	19/14/10	28/24/19.5	28/24/19.5	28/24/19.5	35.5/29/24	39/31/24	58	72
External Static Pressure		Pa	30	30	30	30	30	30	30	60	60	60	60	60	100	100
Piping	Connection Type	—	Flare-nut Connection(with Flare Nuts)												Brazing	
	Liquid	mm	φ6.35	φ6.35	φ6.35	φ6.35	φ6.35	φ9.53	φ9.53	φ9.53	φ9.53	φ9.53	φ9.53	φ9.53	φ9.53	φ9.53
		inch	1/4	1/4	1/4	1/4	1/4	3/8	3/8	3/8	3/8	3/8	3/8	3/8	3/8	3/8
	Gas	mm	φ12.7	φ12.7	φ12.7	φ12.7	φ15.88	φ15.88	φ15.88	φ15.88	φ15.88	φ15.88	φ15.88	φ15.88	φ19.05	φ22.2
inch		1/2	1/2	1/2	1/2	5/8	5/8	5/8	5/8	5/8	5/8	5/8	5/8	3/4	7/8	
Condensate Drain	mm	I.D. 32														
Weight	Net Weight	kg	25	25	25	25	30	30	30	45	45	45	52	52	94	106
	Gross Weight	kg	31	31	31	31	36	37	37	52	52	52	61	61	106	111
Dimensions	External	H mm	270	270	270	270	270	270	270	300	300	300	300	300	470	470
		W mm	650+75	650+75	650+75	650+75	900+75	900+75	900+75	1100+75	1100+75	1100+75	1400+75	1400+75	1060	1250
		D mm	720	720	720	720	720	720	720	800	800	800	800	800	800	1120
	Packaging	H mm	385	385	385	385	385	385	385	415	415	415	415	415	546	546
		W mm	895	895	895	895	1140	1140	1140	1345	1345	1345	1640	1640	1276	1466
		D mm	870	870	870	870	870	870	870	950	950	950	950	950	950	1345

Notes:

1. The nominal cooling capacity and heating capacity are based on the following conditions:  
 Cooling Operation Conditions  
 Indoor Air Inlet Temperature: 27°C DB(80°F DB), 19.0°C WB(66.2°F WB)  
 Outdoor Air Inlet Temperature: 35°C DB(95°F DB)  
 Piping Length: 7.5 Meters Piping Lift: 0 Meter  
 Heating Operation Conditions  
 Indoor Air Inlet Temperature: 20°C DB(68°F DB)  
 Outdoor Air Inlet Temperature: 7°C DB(45°F DB), 6°C WB(43°F WB)

2. The sound pressure level is based on the following conditions: 1.5m beneath the unit.  
 With discharge duct (2.0m) and return duct(1.0m)  
 The above data was measured in an anechoic chamber so that the reflected sound should be taken into consideration in the field.

3. When bottom air inlet is adopted, the sound pressure will increase according to factors such as installation mode and the room structure.



## Wall Mounted Type

### High-efficiency DC Fan Motor

The power consumption of the unit with DC fan motor can be reduced greatly in comparison to the old AC product. The minimum power consumption is only 20W, which is reduced by 60%. It can achieve low-cost operation.

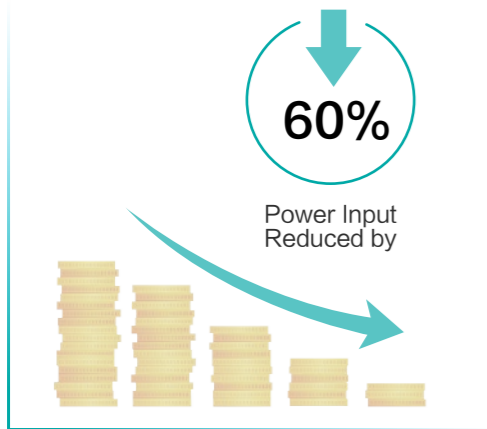

### 6 Fan Speed

6 indoor fan speeds are available to meet the needs of different indoor conditions.

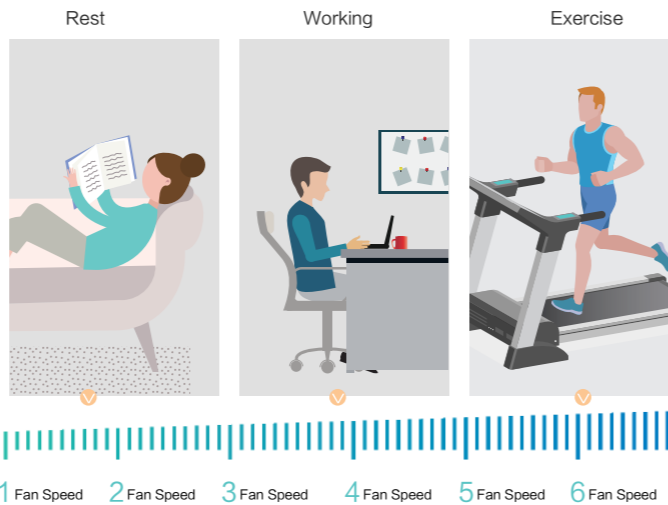

### Optimal Noise Control

The low-noise DC fan motor and the enhanced vibration pad on the distribution pipe and EEV will ensure a quieter operation. Besides, with Hisense special smart noise reduction technology, the operation noise can also be decreased effectively. During the high airflow operation, maximum 5dB(A)\* is decreased compare with the previous generation. What's more, sleep mode and quiet mode are also available for users to further enjoy a quiet environment.

\*Take AVS-12\* as an example



### Self-cleaning Function

Featured with self-cleaning technology, the evaporator can be self-cleaned automatically just with the tap of a button in the controller, which is very convenient and saves the cost of manual cleaning, while ensuring a clean environment.

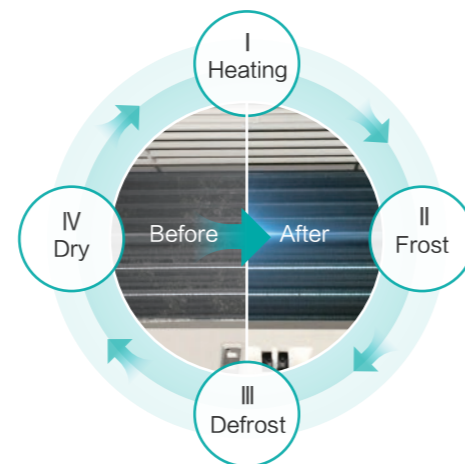

4 processes for deep cleaning

## Wall Mounted Type



Model		AVS-05 HJFTDD	AVS-07 HJFTDD	AVS-09 HJFTDD	AVS-12 HJFTDD	AVS-15 HJFTDD	AVS-18 HJFTDD	AVS-24 HJFTDD	AVS-28 HJFTDD	
Power Supply		AC 1ϕ, 220~240V/50Hz; AC 1ϕ, 220V/60Hz								
Capacity	Cooling	kW	1.7	2.2	2.8	3.6	4.5	5.6	7.1	8.4
		Btu/h	5,800	7,500	9,600	12,300	15,400	19,100	24,200	28,700
	Heating	kW	2.0	2.5	3.3	4.0	5.0	6.3	8.0	8.4
		Btu/h	6,500	8,500	11,300	13,700	17,100	21,500	27,300	28,700
Power Input	Cooling	W	20	20	20	30	20	30	50	80
	Heating	W	20	20	20	30	30	30	70	80
Sound Pressure		dB(A)	33/32/32/ 30/30/28	36/35/33/ 32/30/28	36/35/33/ 32/30/28	38/35/33/ 32/30/28	38/37/36/ 32/31/29	40/38/36/ 35/33/31	45/42/41/ 38/35/31	50/48/45/ 41/36/33
Airflow Rate		m <sup>3</sup> /min	8.7/8.3/8.2/ 7.5/7.2/7.0	9.8/9.2/8.7/ 8.2/7.5/7.0	9.8/9.2/8.7/ 8.2/7.5/7.0	10.3/9.2/8.7/ 8.2/7.5/7.0	11.5/11.0/10.3/ 9.0/8.7/8.0	16.2/15.0/14.2/ 13.3/12.2/11.5	20.0/18.0/17.0/ 15.0/13.3/11.7	23.3/22.0/20.0/ 17.0/14.2/12.2
Panel Colour		-	White							
Piping		Connection Type	Flare Nuts							
	Liquid	mm	ϕ6.35	ϕ6.35	ϕ6.35	ϕ6.35	ϕ6.35	ϕ9.53	ϕ9.53	ϕ9.53
		inch	1/4	1/4	1/4	1/4	1/4	3/8	3/8	3/8
	Gas	mm	ϕ9.53	ϕ9.53	ϕ9.53	ϕ9.53	ϕ12.7	ϕ15.88	ϕ15.88	ϕ15.88
		inch	3/8	3/8	3/8	3/8	1/2	5/8	5/8	5/8
	Drain Pipe	mm	O.D. 18							
Weight	Net Weight	kg	9	9	9	9	13	14.5	14.5	14.5
	Gross Weight	kg	12.5	12.5	12.5	12.5	17	19	19	19
Dimensions	External	H mm	270	270	270	270	315	315	315	315
		W mm	845	845	845	845	960	1120	1120	1120
		D mm	203	203	203	203	230	230	230	230
	Packaging	H mm	375	375	375	375	430	430	430	430
D mm		310	310	310	310	328	328	328	328	

Notes:

1. The rated capacity is based on the following conditions:  
Cooling conditions: indoor air inlet temperature: 27°C DB, 19°C WB, outdoor air inlet temperature: 35°C DB, pipe length: 7.5m, pipe height difference: 0m  
Heating conditions: indoor air inlet temperature: 20°C DB, outdoor air inlet temperature: 7°C DB, 6°C WB, pipe length: 7.5m, pipe height difference: 0m

2. The above noise values are measured in an anechoic chamber so that reflected sound should be taken into consideration during actual operation.  
The above noise values are measured under the fan mode operation, and measured at a point 1m in front of the unit and 0.8m below the unit.

## Ceiling & Floor Type

### Sleek Smooth Design

Shiny white cover panel of the unit has a streamlined elegant aesthetic. The bolts and nuts used to secure the unit onto wall or ceiling are designed to be concealed in the unit for a sleek room interior look.



### Flexible Installation

The unit can be installed to be standing on floors or hanging on ceilings. Whereby interior walls maximized to display items, can hang the unit on the ceiling.



Hanging on the wall

Standing on the floor

### Wide Air Supply

Louvers consist of horizontal and vertical flaps to cover larger coverage area to the edges of any rooms. Wider opening angle from up to 120° for vertical louvers and up to 71° for horizontal louvers supply air further and lower down to floor needed during heating modes.

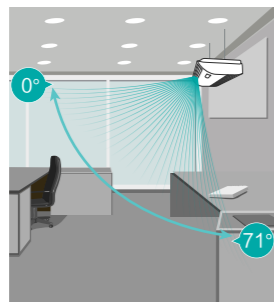
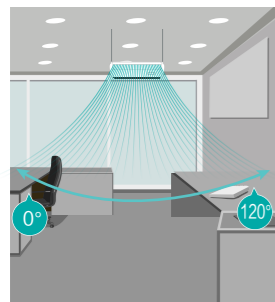

### Convenient Installation and Maintenance

Adjust the ceiling or wall mounting height by just opening the side panels without the need to access the internal parts. Service manholes are unnecessary due to the strategic repositioning of piping connections and electrical box behind the air return panel, service and clean the filter all in the same compartment.

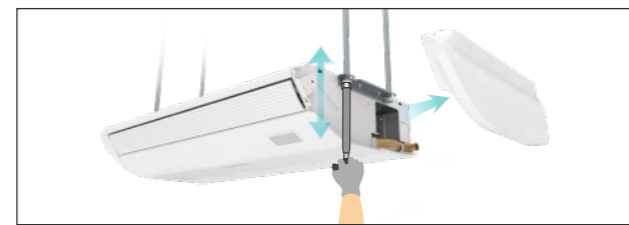

## Ceiling & Floor Type



Model			AVV-17URSCA	AVV-18URSCA	AVV-22URSCA	AVV-24URSCA	AVV-27URSCB	AVV-30URSCB	AVV-38URSCB	AVV-48URSCC
Power Supply			AC 1Φ, 220V-240V/50Hz/60Hz							
Capacity	Cooling	kW	5.0	5.6	6.3	7.1	8.4	9.0	11.2	14.2
		Btu/h	17,100	19,100	21,500	24,200	28,700	30,700	38,200	48,500
Power Input	Cooling	W	40	40	70	70	70	80	130	160
		Sound Pressure	dB(A)	39/35/30	39/35/30	45/41/37	45/41/37	43/39/34	45/40/36	51/46/40
Sound Pressure	Ceiling	dB(A)	39/35/30	39/35/30	45/41/37	45/41/37	43/39/34	45/40/36	51/46/40	50/46/42
	Floor	dB(A)	43/38/35	43/38/35	48/44/40	48/44/40	46/41/37	48/43/39	54/49/43	55/50/46
Air Flow Rate		m³/min	13.0/11.0/9.0	13.0/11.0/9.0	16.1/14.0/11.3	16.1/14.0/11.3	18.2/15.2/12.2	19.4/16.3/13.3	24.8/20.5/16.3	33.0/28.0/23.0
Speed-up Setting HH1		m³/min	14.2	14.2	17.8	17.8	19.8	21.2	27.0	36.0
Speed-up Setting HH2		m³/min	16.0	16.0	20.0	20.0	22.3	23.5	29.2	37.4
Panel Colour		-	Neture White	Neture White	Neture White	Neture White	Neture White	Neture White	Neture White	Neture White
Piping	Connection Type	-	Flare-nut Connection(with Flare Nuts)							
	Liquid	mm	φ 6.35	φ 6.35	φ 9.53	φ 9.53	φ 9.53	φ 9.53	φ 9.53	φ 9.53
		inch	1/4	1/4	3/8	3/8	3/8	3/8	3/8	3/8
	Gas	mm	φ 15.88	φ 15.88	φ 15.88	φ 15.88	φ 15.88	φ 15.88	φ 15.88	φ 15.88
		inch	5/8	5/8	5/8	5/8	5/8	5/8	5/8	5/8
Condensate Drain	mm	I.D.32								
Weight	Net Weight	kg	31	31	32	32	39	40	41	47
	Gross Weight	kg	38	38	39	39	46	47	48	56
Dimensions	External	H mm	230	230	230	230	230	230	230	230
		W mm	990	990	990	990	1285	1285	1285	1580
		D mm	680	680	680	680	680	680	680	680
	Packaging	H mm	340	340	340	340	340	340	340	340
		W mm	1110	1110	1110	1110	1400	1400	1400	1690
		D mm	830	830	830	830	830	830	830	830

NOTES:

1. The nominal cooling capacity is based on the following conditions:  
 Indoor Air Inlet Temperature: 27°C DB(80°F DB), 19.0°C WB(66.2°F WB)  
 Outdoor Air Inlet Temperature: 35°C DB(95°F DB)  
 Piping Length: 7.5 Meters Piping Lift: 0 Meter

2. The sound pressure level is based on the following conditions:  
 1.0m beneath the unit, 1.0m from Discharge Grille.  
 The above data was measured in an anechoic chamber so that the reflected sound should be taken into consideration in the field. When bottom air inlet is adopted, sound pressure will increase according to factors such as installation mode and the room structure.

## Floor Concealed Type

### Space Saving

Floor concealed units are designed to be installed on floors completely concealed into the walls which designed to be slim and compact with only height of 620mm to be hidden under half-heighted windows.



### Adjustable Static Pressure and Flexible Installation

With 2-level external static pressure adjustable, project design and installation are more flexible. Users can choose the air duct to increase the air supply distance in order to achieve the completely concealed installation.

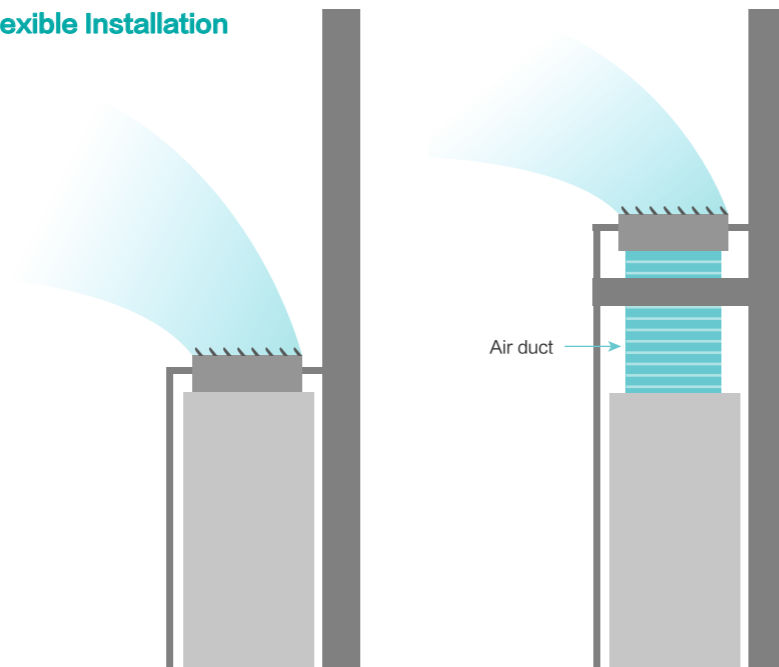

## Floor Concealed Type

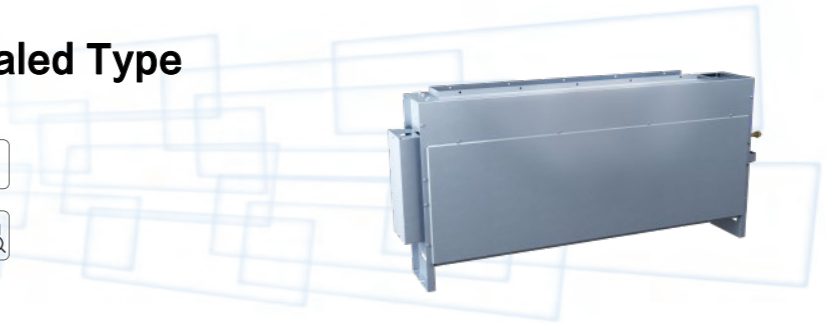
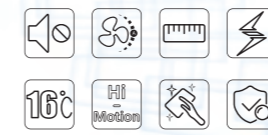

Model			AVH-09UXCSAA	AVH-14UXCSAA	AVH-18UXCSBA	AVH-24UXCSBA
Power Supply			AC 1ϕ, 220V-240V/50Hz			
Model			AVH-09UX2SAA	AVH-14UX2SAA	AVH-18UX2SBA	AVH-24UX2SBA
Power Supply			AC 1ϕ, 220V/60Hz			
Capacity	Cooling	kW	2.8	4.3	5.6	7.1
		Btu/h	9,600	14,700	19,100	24,200
Power Input	Cooling	W	50	80	90	120
Sound Pressure		dB(A)	34/31/27	40/36/34	41/36/32	44/40/36
Air Flow Rate		m <sup>3</sup> /min	8.5/7.5/6.3	10.3/9.0/8.0	14.8/12.3/10.5	16.3/13.8/11.8
Piping	Connection Type	-	Flare-nut Connection(with Flare Nuts)			
	Liquid	mm	ϕ 6.35	ϕ 6.35	ϕ 6.35	ϕ 9.53
		inch	1/4	1/4	1/4	3/8
	Gas	mm	ϕ 12.7	ϕ 12.7	ϕ 15.88	ϕ 15.88
		inch	1/2	1/2	5/8	5/8
Condensate Drain	mm	I.D.32				
Weight	Net Weight	kg	18	22	26	27
	Gross Weight	kg	30	31	37	37
Dimensions	External	H mm	620	620	620	620
		W mm	948+139	948+139	1218+139	1218+139
		D mm	202	202	202	202
	Packaging	H mm	675	675	675	675
		W mm	1160	1160	1430	1430
		D mm	240	240	240	240

NOTES:

1. The nominal cooling capacity is based on the following conditions:  
Indoor Air Inlet Temperature: 27°C DB(80°F DB), 19.0°C WB(66.2°F WB)  
Outdoor Air Inlet Temperature: 35°C DB(95°F DB)  
Piping Length: 7.5 Meters Piping Lift: 0 Meter

2. The sound pressure level is based on the following conditions:  
1.5m meters from the unit and 1.5m meters from floor level.  
The above data was measured in an anechoic chamber so that reflected sound should be taken into consideration in the field.

## All Fresh Air Indoor Unit

### Space Saving

Fresh air unit consisting of height of 370mm only requires small amount of ceiling space and fits into complicated kitchen ceilings with various exhaust duct connections.

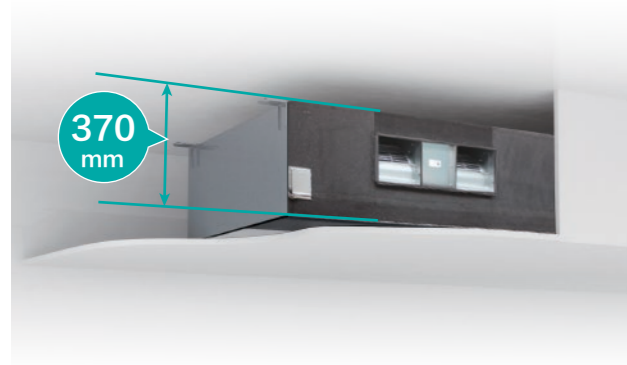

### Larger Airflow Rate & Static Pressure Options

The total amount of fresh air units could be reduced with larger capacity, large airflow rate per unit. With the reduced amount of units, fresh air ducts often need to be supply to the furthest room. Hence achievable with high static pressures offered.

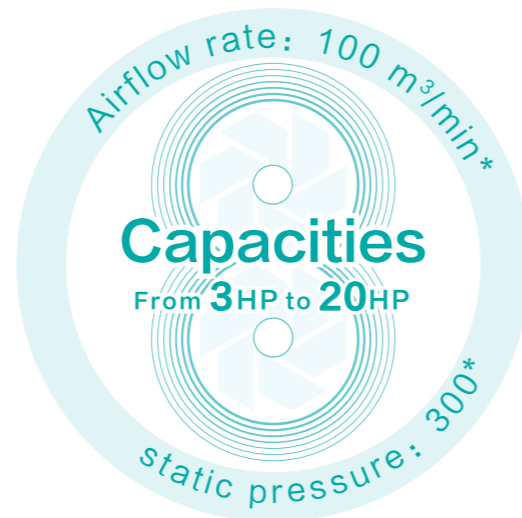

\*Note: only specific model can reach this figure.

## Simple & Flexible Piping System

Fresh air from the units could be pre-cooled connecting to the same refrigerant systems with other indoor units, introducing cooled or warm fresh air directly without overburdening other fan coil units.



## All Fresh Air Indoor Unit



Model		AVA-30UX CSCH-70	AVA-48UX CSQH-108	AVA-76UX CSRH-168	AVA-96UX CSRH-210	AVA-114UX 6SRH-300	AVA-154UX 6SSH-400	AVA-190UX 6STH-500	AVA-190UX 6STH-600	
Power Supply		AC 1Φ, 220V-240V/50Hz				AC 3Φ, 380V-415V/50Hz				
Model		AVA-30UX 2SCH-70	AVA-48UX 2SQH-108	AVA-76UX 2SRH-168	AVA-96UX 2SRH-210	AVA-114UX 7SRH-300	AVA-154UX 7SSH-400	AVA-190UX 7STH-500	AVA-190UX 7STH-600	
Power Supply		AC 1Φ, 220V/60Hz				AC 3Φ, 380V/60Hz				
Capacity	Cooling	kW	9.0	14.0	22.4	28.0	33.5	45.0	56.0	56.0
		Btu/h	30,700	47,800	76,500	95,600	114,300	153,600	191,100	191,100
Power Input	Cooling	W	150(140*)	330(310*)	490(610*)	510(710*)	740(700*)	1120(1070*)	1330(1270*)	1620(1540*)
Sound Pressure		dB(A)	32	43	45	46	56	61	64	66
Air Flow Rate		m³/min	11.0	18.0	28.0	35.0	50.0	66.7	83.3	100.0
External Static Pressure		Pa	60(120)	200	220	220	220	300	320	300
Piping	Connection Type	-	Flare-nut Connection(with Flare Nuts)			Brazing				
	Liquid	mm	Φ 9.53	Φ 9.53	Φ 9.53	Φ 9.53	Φ 12.7	Φ 12.7	Φ 15.88	Φ 15.88
		inch	3/8	3/8	3/8	3/8	1/2	1/2	5/8	5/8
	Gas	mm	Φ 15.88	Φ 15.88	Φ 19.05	Φ 22.2	Φ 25.4	Φ 25.4	Φ 28.6	Φ 28.6
		inch	5/8	5/8	3/4	7/8	1	1	1-1/8	1-1/8
Condensate Drain	mm	I.D.32				RC1 (Internal Screw)				
Weight	Net Weight	kg	46	60	97	97	97	196	222	222
	Gross Weight	kg	51	64	117	117	117	240	267	267
Dimensions	External	H mm	370	370	486	486	486	635	735	735
		Wmm	920	1320	1270	1270	1270	1950	1950	1950
		D mm	800	800	1069	1069	1069	805	805	805
	Packaging	H mm	390	390	1290	1290	1290	816	916	916
		Wmm	1112	1512	1466	1466	1466	2213	2213	2213
		D mm	922	922	540	540	540	1006	1006	1006
Temperature Range of Fresh Air		-	Cooling: 20°C-43°C							

NOTES:

- The nominal cooling capacity is based on following conditions  
Cooling operation conditions: 33°C DB, 28°C WB, piping length: 7.5m, piping lift: 0m
- The sound pressure level is based on following conditions: 1.5 Meter beneath the unit.  
The above data was measured in an anechoic chamber so that reflected sound should be taken into consideration in the filed.
- An air filter with duct collection efficiency more than 50% needs to be attached to the duct system of the suction side at site.
- Under cooling mode, when outdoor temperature is lower than 20° C, the system will automatically shift to ventilation operation.

\*1: the parameter of indoor units with power supply of 60Hz

# Heat Recovery Ventilator

## Compact Machine, Convenient Installation.

The thickness of machine can be easily installed in the narrow residential ceiling. The width of the machine whose volume is under 300 m<sup>3</sup>/h is less than 600mm, which is particularly suitable for very narrow spaces in the ceiling, and can save the space of installation, it is more convenient for construction.

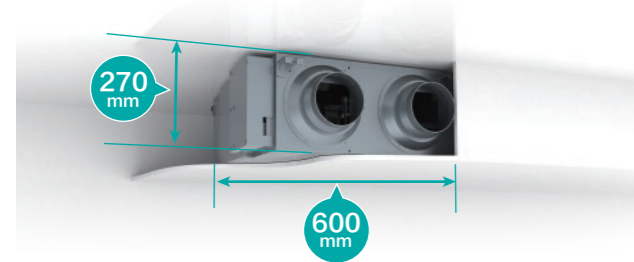

## Airflow System

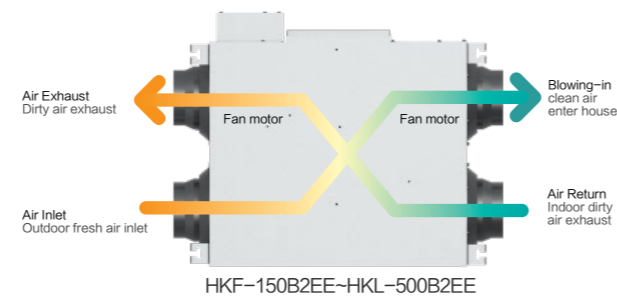
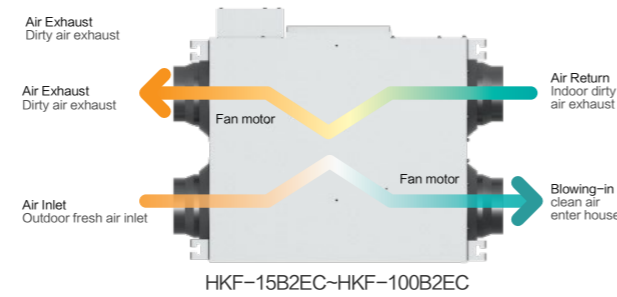

## Centralized Control System

Hisense centralized control type total heat exchanger products can be connected to the centralized control system of Hisense air conditioning, achieve the linkage with air conditioning system and centralized control, so the operation is more convenient and more intelligent!

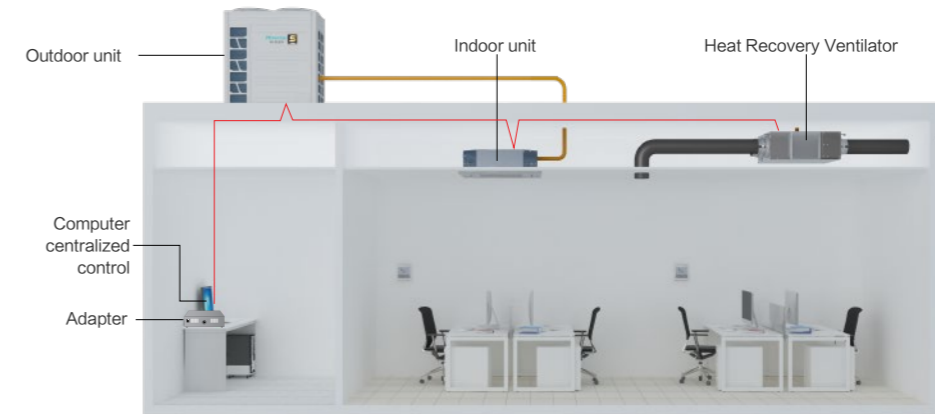

## Energy Saving Analysis

### Summer Energy Saving Analysis

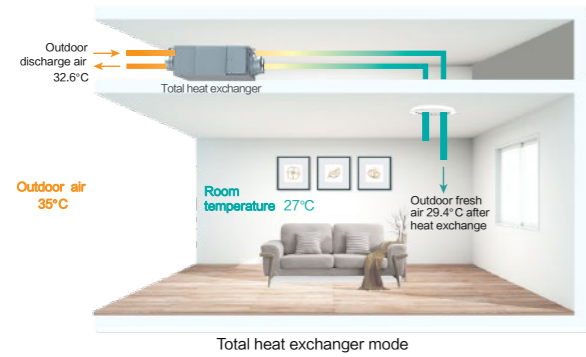

In summer operation, when the cold energy of 27°C air discharged from indoor pass through the heat exchanger, the 35° C outdoor hot air is pre-cooled to 29.4°C fresh air and supplied to indoors, as shown above, the air conditioner only needs to cool the air by 2.4°C to maintain a comfortable room temperature and fresh air. In this process, the discharge air pre-cools the fresh air by HRV, The temperature recovery efficiency in cooling is 70% max, and enthalpy exchange efficiency is 57% max.

### Winter Energy Saving Analysis

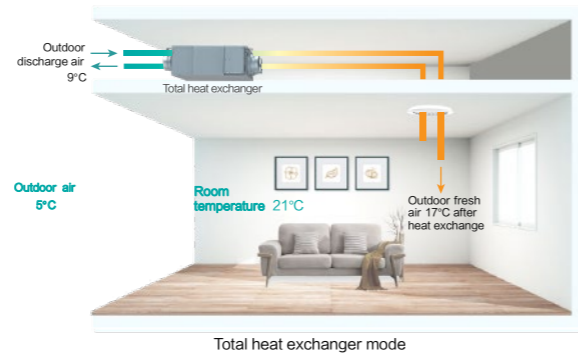

In winter operation, when the heat energy of 21°C air discharged from indoor pass through the heat exchanger, the 5°C outdoor cold air is pre-heated to 17°C fresh air and supplied to indoors, as shown above, when outdoor 5°C air and indoor 21°C air pass through the HRV, the fresh air supplied to indoors is about 17°C, the air conditioner only needs to heat the air by 4°C to maintain a comfortable room temperature and fresh air. The temperature recovery efficiency in heating is 75% max, and enthalpy exchange efficiency is 63% max.

## HKF-15B2EC

### Product Dimensions

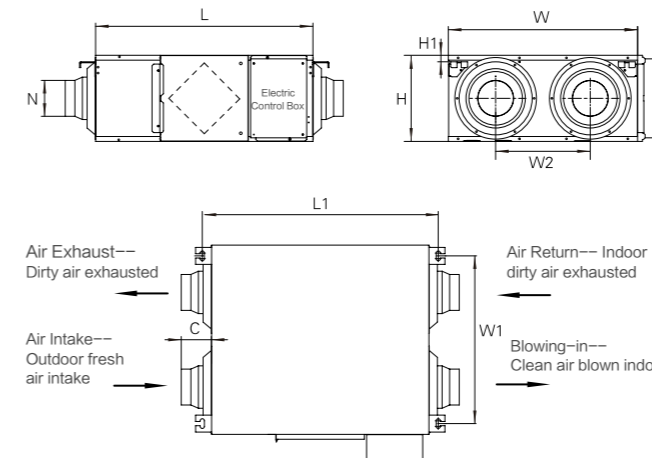

Model	L	L1	W	W1	W2	H	C	N	H1
HKF-15B2EC*	665	723	580	514	290	265	90	Φ144	20

### Technical Parameters

Model	Air Volume m <sup>3</sup> /h			Enthalpy Efficiency (Summer) η <sub>i</sub>			Enthalpy Efficiency (Winter) η <sub>i</sub>			External Static Pressure Pa			Power Supply	Input Current A			Input Power kW			Noise Level dB(A)			Weight kg
	High	Middle	Low	High	Middle	Low	High	Middle	Low	High	Middle	Low		High	Middle	Low	High	Middle	Low				
HKF-15B2EC*	150	150	110	58	58	60	65	65	69	85	70	65	220-240V/50Hz	0.38	0.36	0.31	2×0.041	2×0.038	2×0.029	30	29	28	25

\*: 220V/60Hz HKF-15B2E2

## HKF-25B2EC~HKF-100B2EC

### Product Dimensions

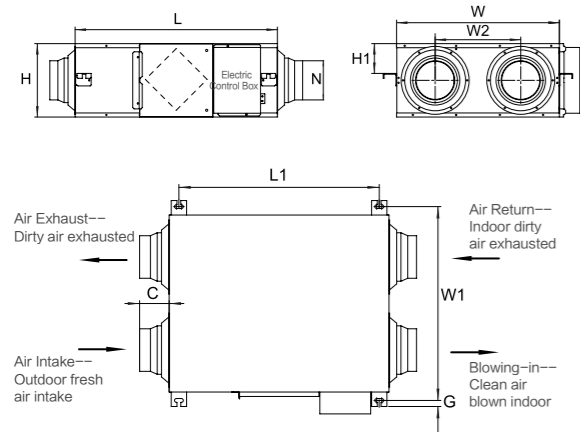

Model	L	L1	W	W1	W2	H	C	G	N	H1
HKF-25B2EC*	745	675	600	656	315	270	90	19	Φ144	110
HKF-35B2EC*	745	675	805	861	480	270	90	19	Φ144	110
HKF-50B2EC*	825	755	905	961	500	270	96	19	Φ194	110
HKF-65B2EC*	1115	1050	885	941	430	390	80	19	Φ242	175
HKF-80B2EC*	1115	1050	1135	1191	675	390	80	19	Φ242	175
HKF-100B2EC*	1115	1050	1135	1191	675	390	80	19	Φ242	175

### Technical Parameters

Model	Air Volume m <sup>3</sup> /h			Enthalpy Efficiency (Summer) η <sub>i</sub>			Enthalpy Efficiency (Winter) η <sub>i</sub>			External Static Pressure Pa			Power Supply	Input Current A			Input Power kW			Noise Level dB(A)			Weight kg
	High	Middle	Low	High	Middle	Low	High	Middle	Low	High	Middle	Low		High	Middle	Low	High	Middle	Low	High	Middle	Low	
HKF-25B2EC*	250	250	190	57	57	59	63	63	68	85	65	60	220-240V 50/60Hz	0.66	0.56	0.52	2×0.069	2×0.055	2×0.049	32	31	28	30
HKF-35B2EC*	350	350	270	55	55	57	62	62	65	100	75	65		0.76	0.75	0.71	2×0.083	2×0.079	2×0.075	34	33	31	35
HKF-50B2EC*	500	500	400	56	56	58	63	63	65	130	110	100		1.82	1.71	1.52	2×0.189	2×0.157	2×0.124	39	38	36	40
HKF-65B2EC*	650	650	550	57	57	59	63	63	68	130	100	100		1.75	1.62	1.51	2×0.193	2×0.178	2×0.164	40	38	35	62
HKF-80B2EC*	800	800	650	58	58	59	66	66	68	130	100	90		1.98	1.88	1.75	2×0.211	2×0.196	2×0.18	42	40	37	72
HKF-100B2EC*	1000	1000	700	56	56	58	63	63	66	165	120	60		4.68	4.18	3.47	2×0.510	2×0.450	2×0.363	44	42	38	79

\*: AC 1Φ220V/60Hz HKF-25B2E2-HKF-100B2E2

## HKF-150B2EE~HKF-200B2EE

### Product Dimensions

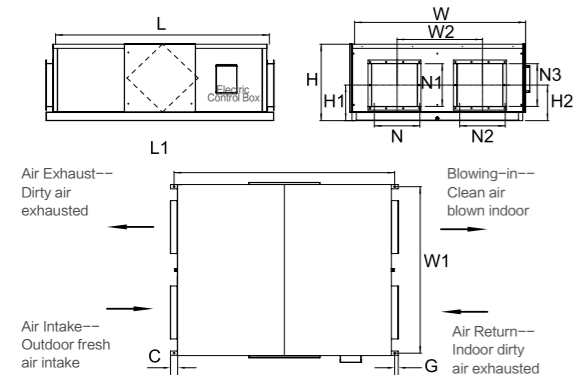

Model	L	L1	W	W1	W2	H	H1
HKF-150B2EE*	1500	1550	1200	1170	600	540	250
HKF-200B2EE*	1550	1600	1400	1370	700	540	250

Model	C	G	N	N1	N2	N3	H2
HKF-150B2EE*	50	25	320	300	320	300	250
HKF-200B2EE*	50	25	320	300	320	300	250

### Technical Parameters

Model	Air Volume m <sup>3</sup> /h	Enthalpy Efficiency (Summer) η <sub>i</sub>	Enthalpy Efficiency (Winter) η <sub>i</sub>	External Static Pressure Pa	Power Supply	Input Current A	Input Power kW	Noise Level dB(A)	Weight kg
HKF-150B2EE*	1500	55	63	180	380-415V/50Hz	2.78	2×0.41	48	151
HKF-200B2EE*	2000	54	62	160	380-415V/50Hz	2.89	2×0.52	49	172

\*: AC 3Φ220V/60Hz HKF-150B2E9 HKF-200B2E9

AC 3Φ380V/60Hz HKF-150B2EF HKF-200B2EF

## HKF-250B2EE~HKF-300B2EE

### Product Dimensions

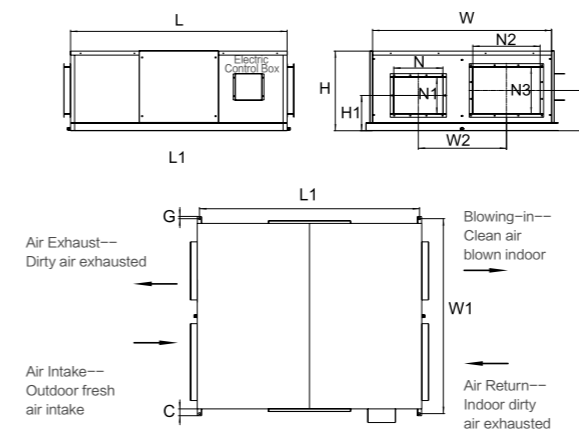

Model	L	L1	W	W1	W2	H	H1
HKF-250B2EE*	1610	1580	1330	1400	655	600	265
HKF-300B2EE*	1700	1670	1500	1570	750	640	272

Model	C	G	N	N1	N2	N3	H2
HKF-250B2EE*	50	15	365	275	500	350	300
HKF-300B2EE*	50	15	365	275	500	350	309

### Technical Parameters

Model	Air Volume m <sup>3</sup> /h	Enthalpy Efficiency (Summer) η <sub>i</sub>	Enthalpy Efficiency (Winter) η <sub>i</sub>	External Static Pressure Pa	Power Supply	Input Current A	Input Power kW	Noise Level dB(A)	Weight kg
HKF-250B2EE*	2500	54	62	180	380-415V/50Hz	3.86	2×0.72	53	185
HKF-300B2EE*	3000	55	63	200	380-415V/50Hz	5.12	2×1.16	56	222

\*: AC 3Φ220V/60Hz HKF-250B2E9 HKF-300B2E9 AC 3Φ380V/60Hz HKF-250B2EF HKF-300B2EF

## HKL-400B2EE~HKL-500B2EE

### Product Dimensions

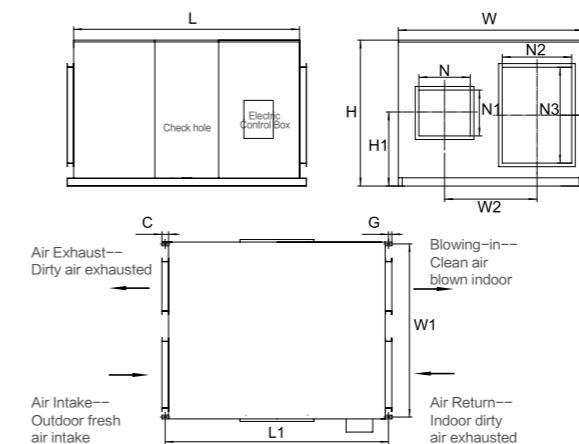

Model	L	L1	W	W1	W2	H	H1
HKL-400B2EE*	1625	1675	1330	1300	665	1050	490
HKL-500B2EE*	1625	1675	1330	1300	665	1050	490

Model	C	G	N	N1	N2	N3	H2
HKL-400B2EE*	50	25	370	330	500	690	475
HKL-500B2EE*	50	25	370	330	500	690	475

### Technical Parameters

Model	Air Volume m <sup>3</sup> /h	Enthalpy Efficiency (Summer) η <sub>i</sub>	Enthalpy Efficiency (Winter) η <sub>i</sub>	External Static Pressure Pa	Power Supply	Input Current A	Input Power kW	Noise Level dB(A)	Weight kg
HKL-400B2EE*	4000	55	63	220	380-415V/50Hz	5.89	2×1.71	57	312
HKL-500B2EE*	5000	53	61	240	380-415V/50Hz	8.78	2×2.2	58	321

\*: AC 3Φ220V/60Hz HKL-400B2E9 HKL-500B2E9 AC 3Φ380V/60Hz HKL-400B2EF HKL-500B2EF

# AHU Connection KIT

## Main Function

- ON/OFF Control
  - Temperature Setting
  - Capacity Demand
  - Operation Mode
- Communication wire   
 —— Sensor signal   
 —— Refrigerant pipe

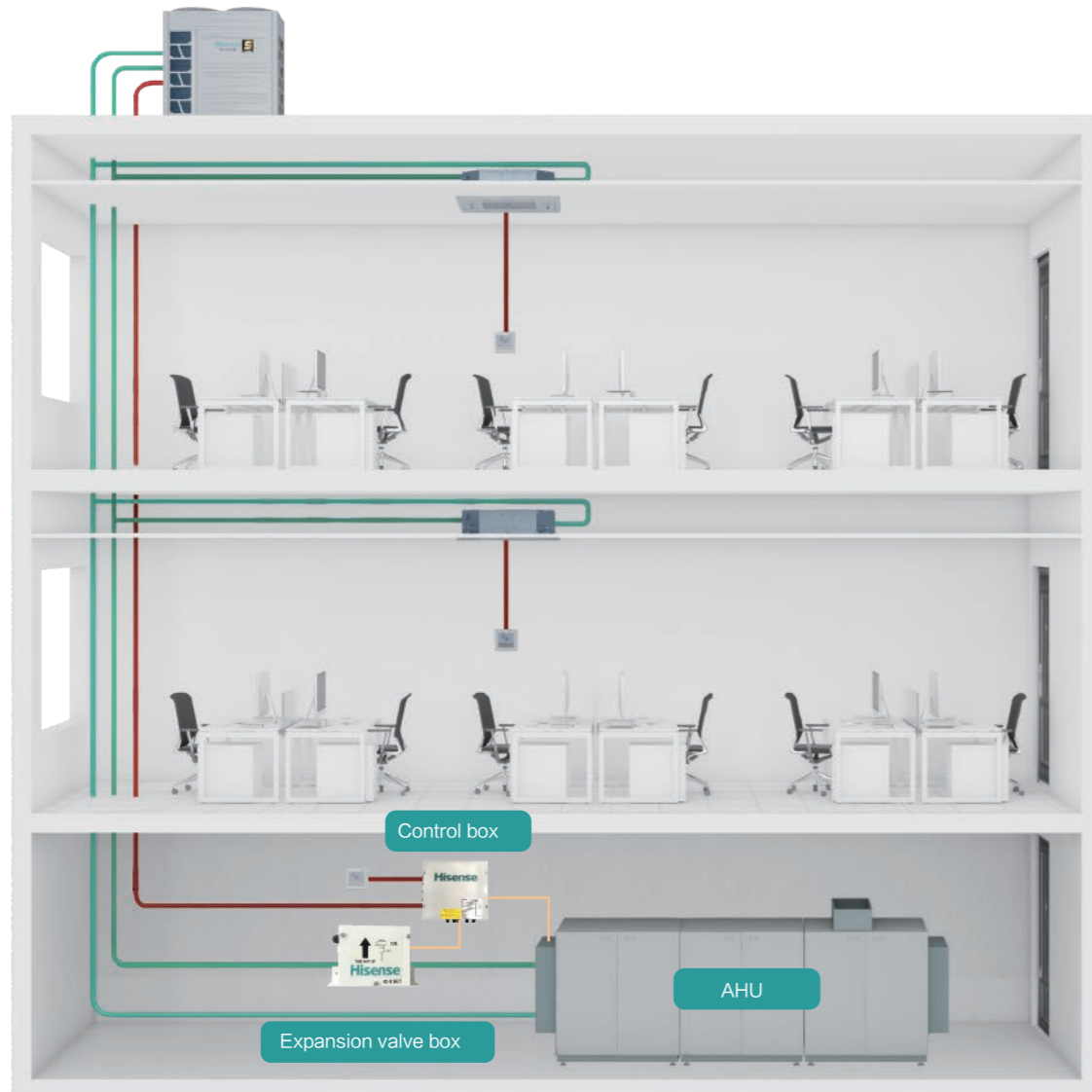

Note: The wired controller HYPE-VA01A is standard.

# AHU Connection KIT

AHU Connection KIT		HZX-2.0 AEC	HZX-4.0 AEC	HZX-6.0 AEC	HZX-10.0 AEC	HZX-20.0 AEC						HZX-30.0 AEC					
Power Supply		AC 1Φ, 220V~240V/50Hz, 220V~240V/60Hz															
Nominal Capacity of AHU		HP	2	4	6	8	10	12	14	16	18	20	22	24	26	28	30
Allowed Heat Exchanger Capacity (H/M/L)	Cooling	kW	4.0	7.1	11.2	16.0	20.0	28.0	33.5	40.0	45.0	50.0	56.0	61.5	69.0	73.0	80.0
		kW	5.0	9.0	14.0	20.0	25.0	30.0	35.0	43.0	48.0	52.0	58.0	65.0	71.0	76.0	82.0
		kW	5.6	11.2	16.0	22.4	28.0	33.5	40.0	45.0	50.0	56.0	61.5	69.0	73.0	80.0	85.0
Heat Exchanger Volume	Min	dm <sup>3</sup>	0.57	1.03	1.92	2.92	3.89	4.76	5.85	6.79	7.57	8.47	9.04	9.50	10.39	11.39	12.36
	Max	dm <sup>3</sup>	1.16	2.37	2.92	3.89	4.76	5.91	6.89	8	8.92	9.97	11.13	12.34	12.89	13.86	14.73
Equivalent Indoor Unit Capacity		HP	2	4	6	8	10	12	14	16	18	20	22	24	26	28	30
Control Box Model		-	HZX-AEC/1														
Expansion Valve Box Model		-	HZX-2.0 AEC/2	HZX-4.0 AEC/2	HZX-6.0 AEC/2	HZX-10.0 AEC/2	HZX-20.0 AEC/2						HZX-30.0 AEC/2set				

Operation conditions		Cooling	
Indoor air inlet temperature	DB	27.0°C	
	WB	19.0°C	
Outdoor air inlet temperature	DB	35.0°C	
	WB	-	

DB: dry bulb; WB: wet bulb  
Pipe Length: 7.5m; pipe height: 0m

# Control System



- Summary
- Wired Controller
- Wireless Controller
- Centralized Controller
- Intelligent Central Control System







COOLING ONLY







## Summary

Model	Wired Controller					Wireless Controller	Central Controller	
	HYXM-VB01A	HYXE-VC01	HYXE-J01H	HYXE-VA01A	HYXE-S01H	HYE-VD01	HYJ-J01H	HYJM-S01H
Picture								
Max. connectable indoor units	6	6	16	16	16	-	128	160
Cooling/Heating/Auto	●	●	●	●	●	●	○	●
Dehumidification	●	●	●	●	●	○	○	●
Fan speed	●	●	●	●	●	●	○	●
Louver setting	●	●	●	●	●	●	○	●
Temperature setting	●	●	●	●	●	●	○	●
Operation monitoring	●	●	●	●	●	●	○	●
24-hour timer	●	●	●	●	●	●	○	●
7-day timer	●	○	●	○	○	○	○	●
Holiday setting	●	○	●	○	○	○	○	●
Main-sub control	●	●	●	●	○	○	○	○
Check function	●	●	●	●	●	○	○	○
Air filter cleaning reminding	●	●	●	●	●	○	○	●
Error code history display	●	●	●	●	●	○	○	●
Auto test run	●	●	●	●	●	●	○	○
Indoor/Outdoor PCB checking	●	●	●	●	●	○	○	○
Self diagnostic function	●	●	●	●	●	●	●	●
Back light	●	●	●	●	●	●	○	●
Built-in temperature sensor	○	●	●	●	○	●	○	○
Wireless control available	●	●	○	○	○	○	○	○
Individual louver control	●	●	●	●	○	●	○	○
Breeze mode	●	●	●	●	○	●	○	○
Motion sensor	●	○	●	●	○	○	○	○
Health(AirPure)	●	●	●	●	○	●	○	○
Hi-Motion	●	○	●	○	○	○	○	○
ECO(energy saving)	●	●	●	●	○	●	○	●
Quiet	●	●	●	●	●	●	○	○
Sleep	●	●	●	●	○	●	○	○
Dry Contact Interface	●	●	●	●	○	○	○	○
3D-air flow	●	●	●	●	○	●	○	○
Self-cleaning	●	●	○	●	○	●	○	○

Remarks: ●Available ○Unavailable



Type		Wired Controller					Wireless Controller
Model		HYXM-VB01A	HYXE-VC01	HYXE-J01H	HYXE-VA01A	HYXE-S01H	HYE-VD01
Picture							
Indoor Unit	4-Way Cassette	●	●	●	●	●	●
	Mini 4-Way Cassette	●	●	●	●	●	●
	1-Way Cassette	●	●	●	●	○	●
	2-Way Cassette	●	●	●	●	○	●
	Ceiling Ducted Type(AC/DC)	●	●	●	●	●	●
	Ceiling Ducted Type(High/Low)	●	●	●	●	●	●
	Console	●	●	●	●	●	▲
	Wall Mounted Type	●	●	●	●	●	▲
	Ceiling & Floor Type	●	●	●	●	●	▲
	Floor Concealed Type	●	●	●	●	○	●
	All Fresh Air	●	●	●	●	●	●
	Heat Recovery Ventilator	●	▲	●	●	●	○
AHU Kit	●	●	●	▲	○	○	

Type		Receiver Kit				Centralized Controller	
Model		HYRE-V02H	HYRE-Z01H	HYRE-T03H	HYRE-X01H	HYJM-S01H	HYJ-J01H
Picture							
Indoor Unit	4-Way Cassette	○	○	●	○	●	●
	Mini 4-Way Cassette	○	●	○	○	●	●
	1-Way Cassette	○	○	○	●	●	●
	2-Way Cassette	●	○	○	○	●	●
	Ceiling Ducted Type(AC/DC)	●	○	○	○	●	●
	Ceiling Ducted Type(High/Low)	●	○	○	○	●	●
	Console	●	○	○	○	●	●
	Wall Mounted Type	●	○	○	○	●	●
	Ceiling & Floor Type	●	○	○	○	●	●
	Floor Concealed Type	●	○	○	○	●	●
	All Fresh Air	●	○	○	○	●	●
	Heat Recovery Ventilator	○	○	○	○	●	●
AHU Kit	○	○	○	○	●	●	

Remarks: ● Optional ○ Incompatible ▲ Standard

Note: All the functions relevant with heating will be absence in all the controllers.

## Wired Controller

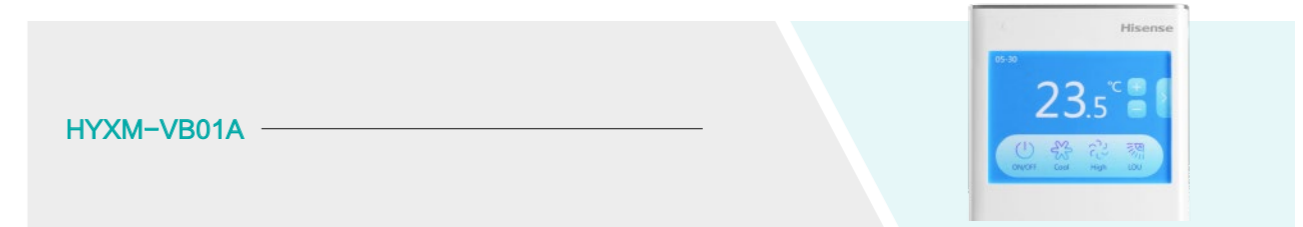

Mode	Cool/Auto/Fan/Dry
Timer	24-hour/Weekly schedule/Holiday setting
Maintenance	Error code / Parameter check/Auto test run/ Indoor&Outdoor PCB checking/Self diagnostic function
Louver	Louver setting/Individual louver control/ 3D-air flow
Special function	Breeze mode/Motion sensor/Health/ Hi-Motion/ECO/Quiet/Sleep/Self-cleaning
Fan speed	6
Temperature setting	0.5°C
Main-sub control	
Air filter cleaning reminding	
Back light	
Wireless control available	

- ### Features
- Size:86mm × 90mm
  - Max. connectable indoor units:6
  - LCD display
  - Touch screen
  - Language:  
VB01A: English,Turkish,Russian,  
German, Arabic,Spanish  
VB01A#01: English,French,Italian,  
Dutch,Polish,Thai

## Colorful Screen

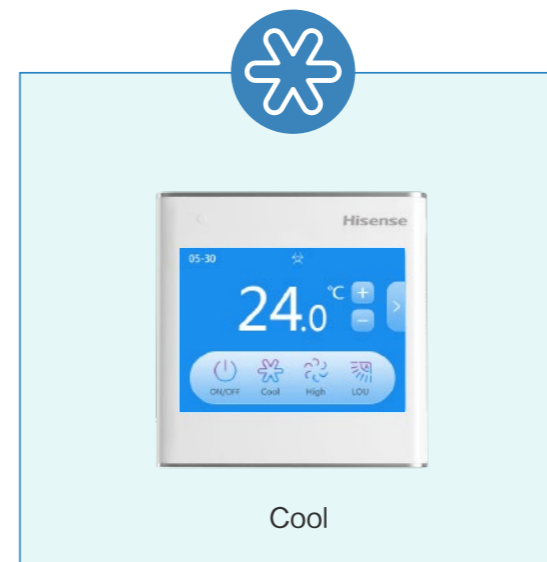

HYXE-VC01



Features

- Size:86mm × 86mm
- Max. connectable indoor units: 6
- LCD display with back light
- Touch button
- Flat back-cover for easy mounting

Mode	Cool/Auto/Fan/Dry
Timer	24-hour
Maintenance	Error code / Parameter check/Auto test run/ Self diagnostic function/Indoor & Outdoor PCB checking/ Air filter cleaning reminding/IDU address setting
Louver	7 Louver setting/3D-air flow/ Individual louver control
Special function	Health/ECO/Quiet/Sleep/Self-cleaning
Fan speed	6
Temperature setting	0.5°C accuracy/Display the setting temp. or room temp.
Main-sub control	•
Wireless control available	•
Built-in temperature sensor	•

HYXE-VA01A



Features

- Size:120mm × 120mm
- Max. connectable indoor units:16
- LCD display
- Touch button

Mode	Cool/Auto/Fan/Dry
Timer	72-hour
Maintenance	Error code / Parameter check/Auto test run/ Indoor&Outdoor PCB checking/Self diagnostic function
Louver	Louver setting/Individual louver control/3D-air flow
Special function	Breeze mode/Motion sensor/Health/ECO/Quiet/ Sleep/Self-cleaning
Fan speed	6
Temperature setting	0.5°C
Main-sub control	
Air filter cleaning reminding	
Back light	
Built-in temperature sensor	

HYXE-J01H



Features

- Size:120mm × 120mm
- Max. connectable indoor units:16
- Touch button
- Language:  
HYXE-J01H: English, Arabic.  
HYXE-J01H1: English, Spanish, Italian,  
German, Polish.  
HYXE-J01H2: English, Turkish,  
Russian, French, Dutch

Mode	Cool/Auto/Fan/Dry
Timer	24-hour/Weekly schedule/Holiday setting
Maintenance	Error code / Parameter check/Auto test run/ Indoor&Outdoor PCB checking/Self diagnostic function
Louver	Louver setting/Louver controlled independently/ 3D-air flow
Special function	Breeze mode/Motion sensor/Health/Hi-Motion/ECO/Mute/Sleep
Fan speed	6
Temperature setting	0.5° C
Main-sub control	
Air filter cleaning reminding	
Back light	
Built-in temperature sensor	

HYXE-S01H



Features

- Size:120mm × 70mm
- Max. connectable indoor units:16
- LCD display
- Touch button

Mode	Cool/Auto/Fan/Dry/Mute
Timer	24-hour
Maintenance	Error code / Parameter check/Auto test run/ Indoor&Outdoor PCB checking/Self diagnostic function
Louver	Louver setting
Fan speed	6
Temperature setting	
Air filter cleaning reminding	

## Wireless Controller

HYE-VD01



### Features

- Size:178.6mm × 47.8mm
- LCD display with back light

Mode	Cool/Auto/Fan/Dry
Timer	24-hour timer
Maintenance	Auto test run/Self diagnostic function/ Identification of adjacent receiver
Louver	Louver setting/3D-air flow/Individual louver control
Special function	Health/ECO/Quiet/Sleep/Self-cleaning
Fan speed	6
Temperature setting	1°C accuracy/Display the setting temp. or room temp.
Built-in temperature sensor	

## Receiver Kit for Wireless Control-Optional

HYRE-X01H



HYRE-V02H

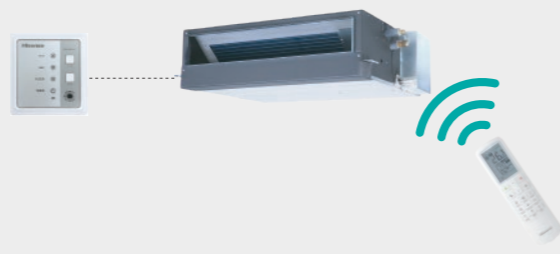

HYRE-Z01H

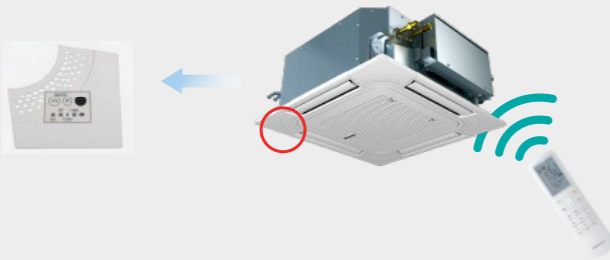

HYRE-T03H

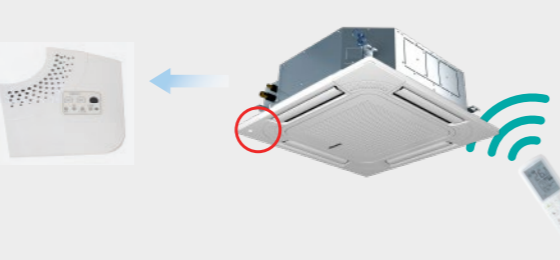

## Centralized Controller

Smart Touch  
HYJM-S01H



### Features

- Size:220mm × 148mm
- Max. connectable indoor units:160
- Max. connectable indoor unit groups:64
- Max. distance:1000m
- Language:  
Chinese, English, Russian,Spanish,  
Turkish,German,Italian,Dutch,Polish,  
Arabic

Cool/Auto/Fan/Dry/ECO
Holiday setting
Filter cleaning reminder
External input/Output function
Temperature limitation
All/4 zone/Individual control

ON/OFF Controller  
HYJ-J01H



### Features

- Size:120mm × 120mm
- Max. connectable indoor units:128
- Max.connectable indoor unit groups:16
- Touch button

Group control (ON/OFF)
Indoor unit power OFF reminder
Indoor units Auto log in
Error reminder

# Intelligent Control



## Convenient Control

- 12 languages available
- Energy management
- 2-level permission
- Online repair
- 7x24 schedule setting
- Customized scenes setting

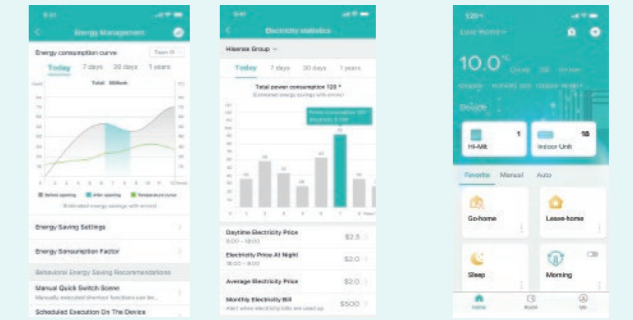

Energy management interface

Customized mode interface

## Anytime and anywhere, control is in your hands

### Brand-new Adapter and App

- Stylish appearance and compact body
- Compatible with VRF, hydro box and heat recovery ventilator
- Supporting OTA update
- Simple and intuitive interfaces

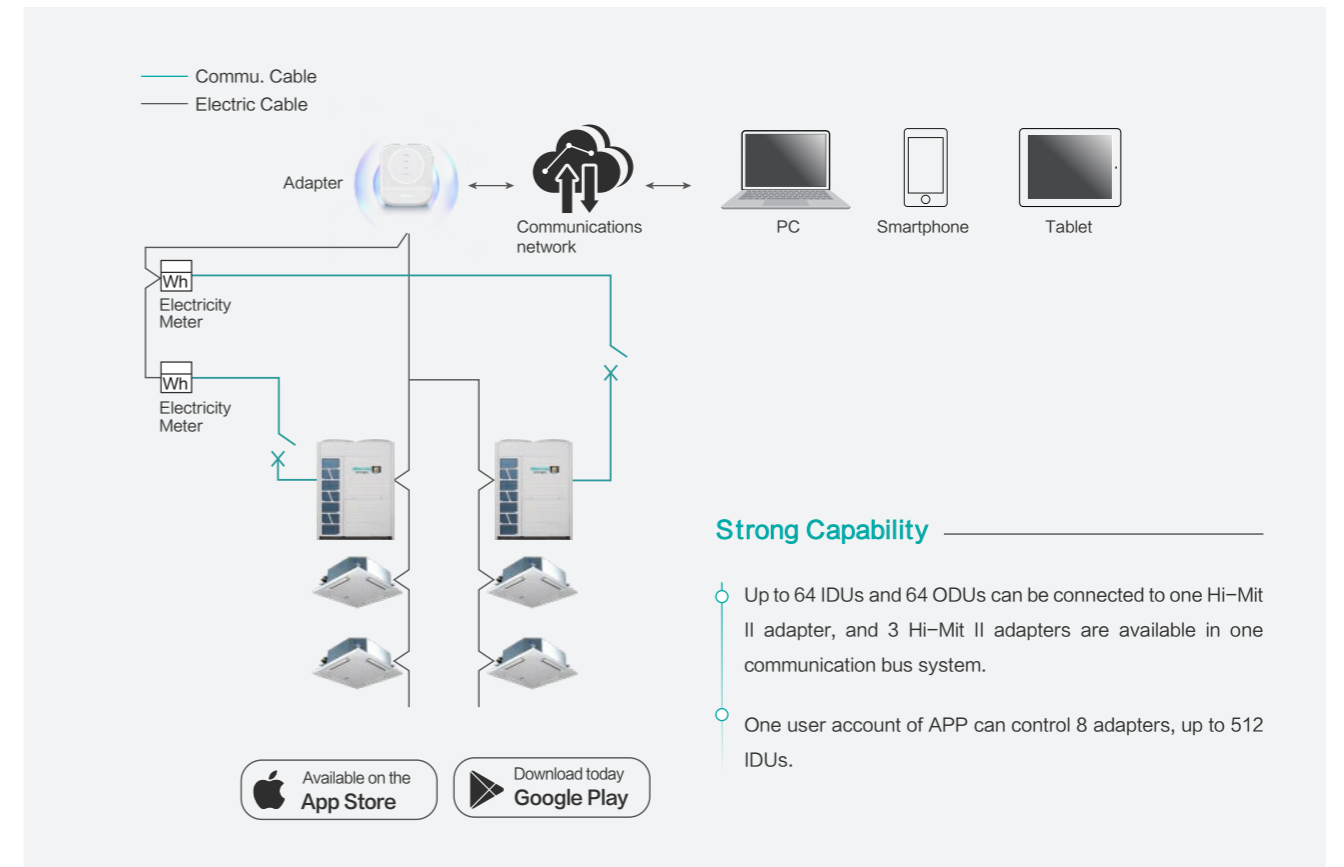
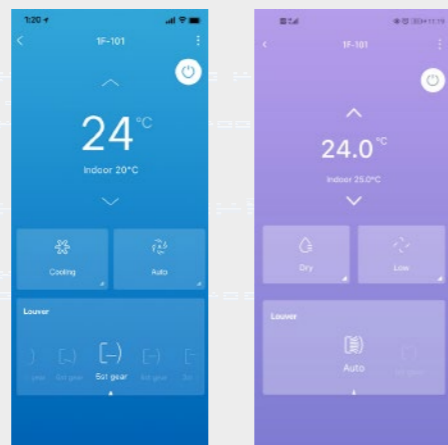

## Strong Capability

- Up to 64 IDUs and 64 ODUs can be connected to one Hi-Mit II adapter, and 3 Hi-Mit II adapters are available in one communication bus system.
- One user account of APP can control 8 adapters, up to 512 IDUs.

## Specifications

Model	Power Supply	Max. Current	Power Input	Dimension	Net Weight
HCCS-H64H2C1M	DC 12V	1A	2.4W	91x117x31mm	0.14kg



Hi-Dom III

Features

- Multilevel user management
- AC control (on-off, mode, temp, air flow)
- AC locked control (running forbidden control, the max. and min. temp and cooling/heating locked)
- Running according to timer
- Malfunction history check
- Running record display
- Data synchronize
- Supporting for external I/O
- 2D navigation
- Electricity consumption allocation

● Humanized interaction interface and comfortable user experience.

● The electricity consumption allocation makes it easy for users to allocate total electricity consumption among building occupants. Both segmented tariff and single tariff are available.

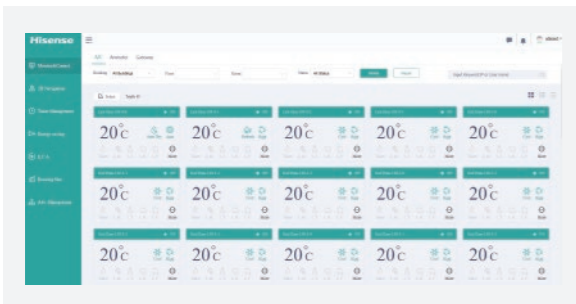

Area	Building	Floor	Room	AC Name	F.P.1 E.	Cost	F.P.2 E.	Cost	F.P.3 E.	Cost	F.P.4 E.	Cost	F.P.5 E.	Cost	Total	Total Co.
1001	1001	2F	401	Low-Risk-VOL	0.04	1.53	0.02	0.32	17.90	14.37	44.59	28.75	61.87	35.94	125.66	73.49
1001	1001	2F	402	Low-Risk-VOL	0.04	1.53	0.02	0.32	17.90	14.37	44.59	28.75	61.87	35.94	125.66	73.49
1001	1001	2F	403	Low-Risk-VOL	0.04	1.53	0.02	0.32	17.90	14.37	44.59	28.75	61.87	35.94	125.66	73.49
1001	1001	2F	404	Low-Risk-VOL	0.04	1.53	0.02	0.32	17.90	14.37	44.59	28.75	61.87	35.94	125.66	73.49
1001	1001	2F	301	Low-Risk-VOL	0.03	1.52	0.21	0.31	17.97	14.30	44.61	28.76	61.86	35.93	125.64	73.48
1001	1001	2F	302	Low-Risk-VOL	0.03	1.52	0.21	0.31	17.97	14.30	44.61	28.76	61.86	35.93	125.64	73.48
Total Check in this Month: 6855.07																
Total Cost: 4322.36																

● Thanks to the 2D navigation, users can import floor plans and place indoor units in the corresponding rooms, creating a tailored system schematic. Thus all the indoor units can be monitored and controlled intuitively.

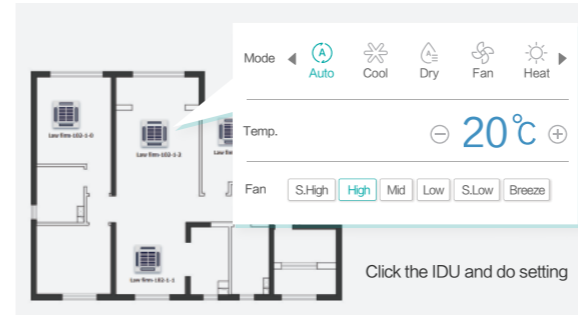

● Support operation history data record like the below picture. Also the operation data can be exported to excel format, convenient for customers to read.

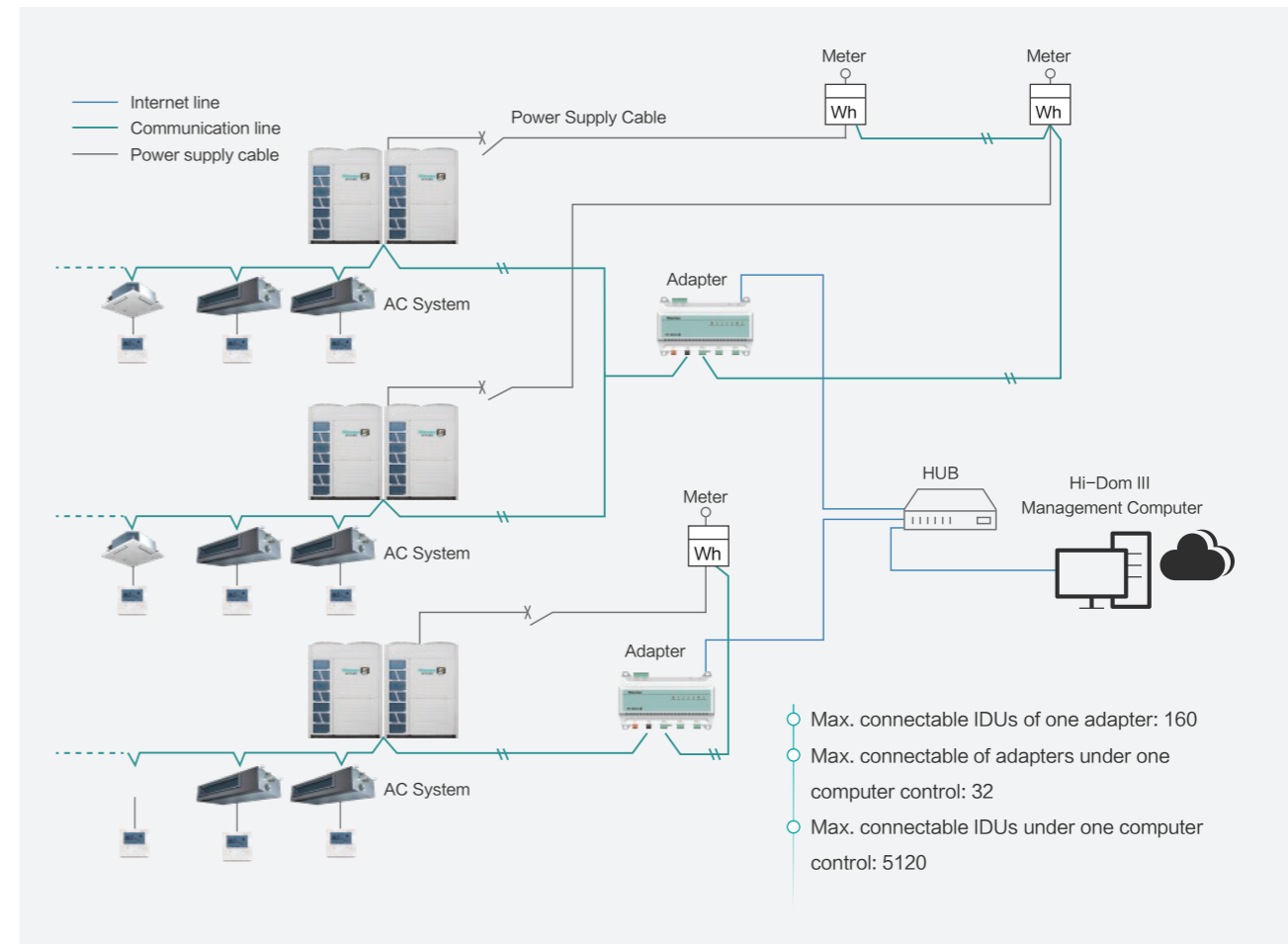
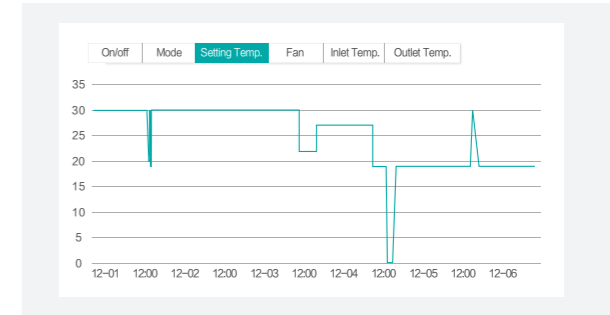

- Max. connectable IDUs of one adapter: 160
- Max. connectable of adapters under one computer control: 32
- Max. connectable IDUs under one computer control: 5120

Specifications

Adapter	Model	Power Supply	Dimension (LxWxD)	Note
	HCCS-H160H2C1YM	12V	180x115.4x64.5mm	With electric charging function
	HCCS-H160H2C1NM	12V	180x115.4x64.5mm	Without electric charging function



## Hi-Checker

### Intelligent service tool, improves your service

Hi-Checker is a plug and play service tool, with which service engineers can access the system and monitor operation status or data, very convenient for system communication and maintenance. Besides, it features cloud-based management, easy to access operation status remotely.



Small and Portable Body



Remote Access



Black Box Function



Powerful Chats



OTA Update

### Easy to Use

- Compact size which allows high portability and space saving.
- Capable to slot in a 32G memory card for data collection and storage. Also the memory card and card reader are standard with Hi-Checker.
- Multiple choices of power supply types. It can be powered by the standard adapter (DC 5V), computer or power bank.
- Support OTA update, ensuring the software is always up to date.



### 4 Ways to Access the Operation Data

- Conventional connection type. The simplest and reliable way by just connecting the Hi-Checker to your computer directly through USB.
- Internet connection type. Be connected to a stable Wi-Fi signal to achieve operation data and status monitoring anytime and anywhere.
- Hotspot connection type. Be connected to a temporary hotspot signal from the smartphone, allowing the Hi-Checker to remotely monitor the operation data when there is no stable Wi-Fi signal on site.
- SD card storage type. Hi-Checker equipped with SD card can be connected to the air conditioning system all the time, so that all the operation data can be stored in the card for later analysis.

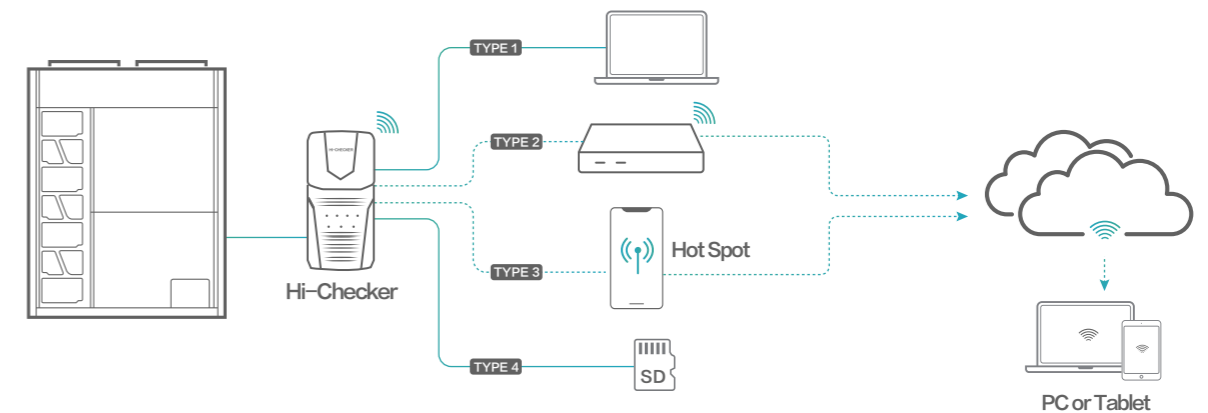

### Easy to Understand

- Powerful and detailed chart analysis on the operation data, allowing users to determine the system condition easily. Together with the smart system diagram, it is interesting and easier for maintenance.
- Users can export the professional report either in .csv or .pdf format, very user-friendly.



### Specifications

Mode	Size (LxWxH)mm	Net Weight (g)	Power Supply	Connectable IDUs
HCCS-H64H2C2M	138x68x28	130	5V= 500mA	160

## Building Management System

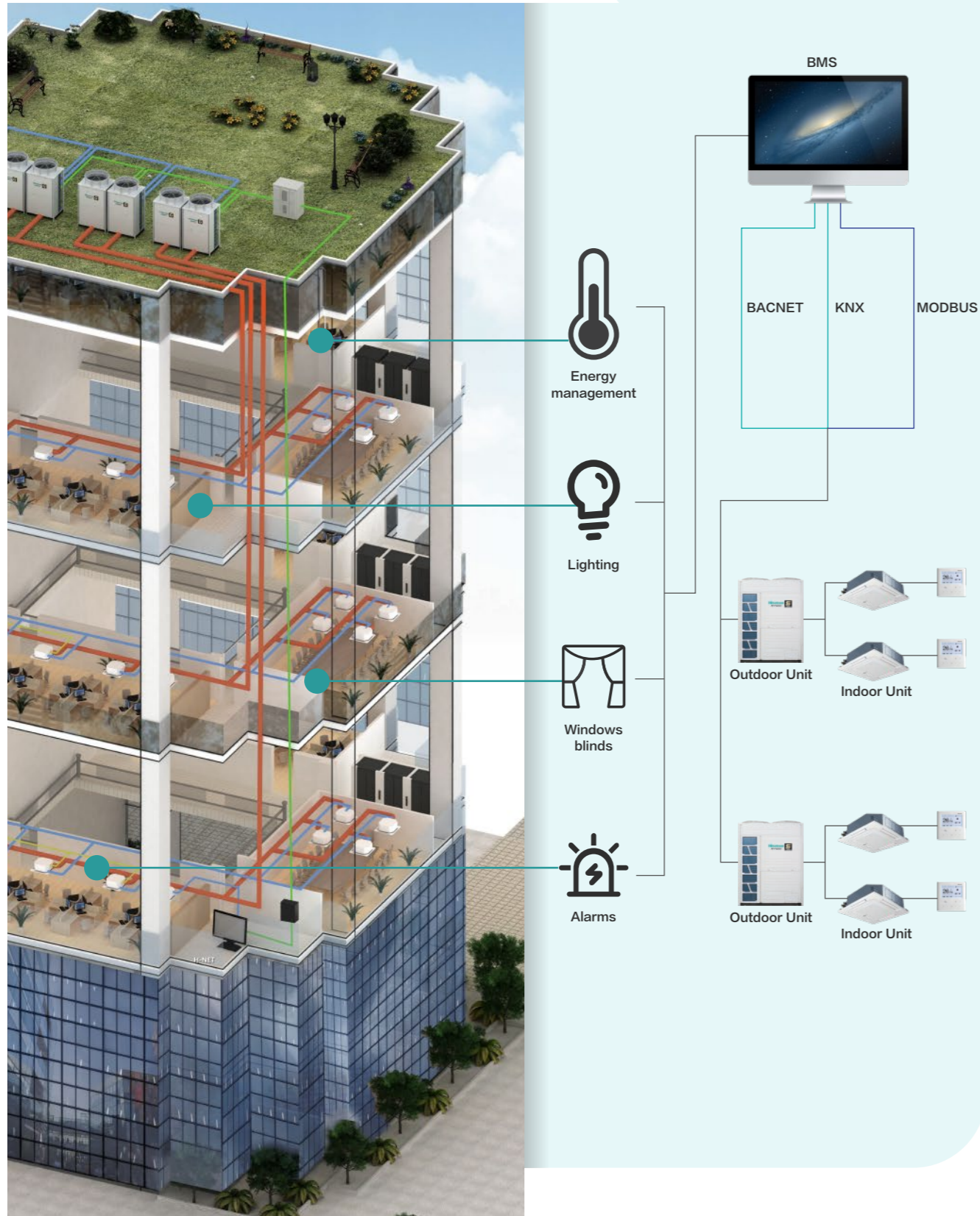

### KNX®

KNX	HS-RC-KNX-1i	HS-AC-KNX-16	HS-AC-KNX-64
Power Supply	DC, 29V	DC, 24V	DC, 24V
Max. Number of Connectable Indoor Units	1	16	64
Dimension (H × W × D)	70 × 70 × 28mm	56 × 88 × 90mm	56 × 88 × 90mm

- Features**
- Standard data point types
  - Error code
  - Central control of all indoor units\*1
  - Easy to use tool for the configuration of Intesis box \*1
  - Directly control of all indoor units\*2
  - Air filter reminder \*2
  - Running hours counter \*2

NOTE\*1: Adapted for HS-AC-KNX-16, HS-AC-KNX-64. \*2: Adapted for HS-RC-KNX-1i.

### Modbus®

MODBUS	HCPC-H2M1C
Power Supply	DC, 12V
Max. Number of Connectable Indoor Units	64
Dimension (H × W × D)	70 × 204 × 240mm

- Features**
- On-Off setting
  - Temperature setting
  - Operating mode setting
  - Inlet air temperature monitoring
  - Airflow setting and monitoring
  - All units On-Off control
  - Alarm monitoring and code display

### BACnet®

BACNET	HS-AC-BAC-16	HS-AC-BAC-64
Power Supply	DC, 24V	DC, 24V
Max. Number of Connectable Indoor Units	16	64
Dimension (H × W × D)	56 × 88 × 90mm	56 × 88 × 90mm

- Features**
- Central control of all indoor units
  - Indoor unit data monitoring
  - Dry/ Fan/ Cool/ Auto mode
  - Control-vane position swing control
  - Function prohibition of wired controller

NOTE: Bacnet® is a registered trademark of American Society of Heating, Refrigerating and Air-conditioning Engineers (ASHRAE).  
Modbus® is a registered trademark of Schneider Electric.  
KNX® is a registered trademark of Konnex.

# Accessory

## Hi-Motion

Model	Applicable Models	Picture
HCM-S01E	All types of indoor units	

## Motion Sensor

Model	Applicable Models	Picture
HPS-MACN	Mini 4-Way Cassette Type	
HCM-01E	4-Way Cassette Type	

## Fresh Air Duct Adapter

Model	Applicable Models	Picture
HFL-56CSA	4-Way Cassette Type and Mini 4-Way Cassette Type	



## Humidity Sensor

Model	Applicable Models	Picture
HCHR-S01E	4-Way Cassette Type, Console, Ceiling Ducted Type, Wall Mounted Type	

## Filter

Filter model	Filter Dimension	Frame Dimension	Application Models	Picture
HF-224L-FE	910 × 432.5mm	1055 × 463mm	AVD-76UX6SEHL	
HF-280L-FE	1100 × 432.5mm	1245 × 463mm	AVD-96UX6SFHL	

## Drain Pump

Model	Applicable Models	Power Supply	Picture
HPS-F133E	AVD-07-24HCFCH / AVD-07-24HCFCL	220-240V/50Hz	
HPS-F363E	AVD-27-54HCFCH / AVD-27-54HCFCL		
HPS-F134E	AVD-07-24H3FCH	208-230V/60Hz	
HPS-F364E	AVD-27-54H3FCH		
HPS-151	All the High/Low Static Pressure Ceiling Ducted Units and All Fresh Air IDU 3-10HP	220-240V/50/60Hz	HPS-F133/363/134/364E HPS-151

## 3D Air-flow Panel

Panel Model	Applicable Models	Outer Dimensions (H × W × D)	Picture
HP-CB-NA	Ceiling ducted type ( DC / AC low-height ) 0.5-1.3HP	180 × 740 × 70mm	
HP-DB-NA	Ceiling ducted type ( DC / AC low-height ) 1.5-1.8HP	180 × 950 × 70mm	
HP-EB-NA	Ceiling ducted type ( DC / AC low-height ) 2-2.5HP	180 × 1220 × 70mm	

## AirPure Kit

Model	Power Supply	Applicable Indoor Units	Picture
HJK-ELZA	AC 1Φ, 220V-240V 50/60Hz	4-Way Cassette Type, Mini 4-Way Cassette Type	
HJK-ELZB	AC 1Φ, 220V-240V 50/60Hz	Ceiling Ducted, Console	

## Voltage Protector

Model	Power Supply	Dimension ( H × W × D )	Picture
HOPT-EOUPA01	AC 3Φ, 380V-415V/50Hz	295 × 222 × 103mm	

## Piping Connection Kit

### Manifold Pipe (For outdoor unit)

(Indoor Unit on Left Side)

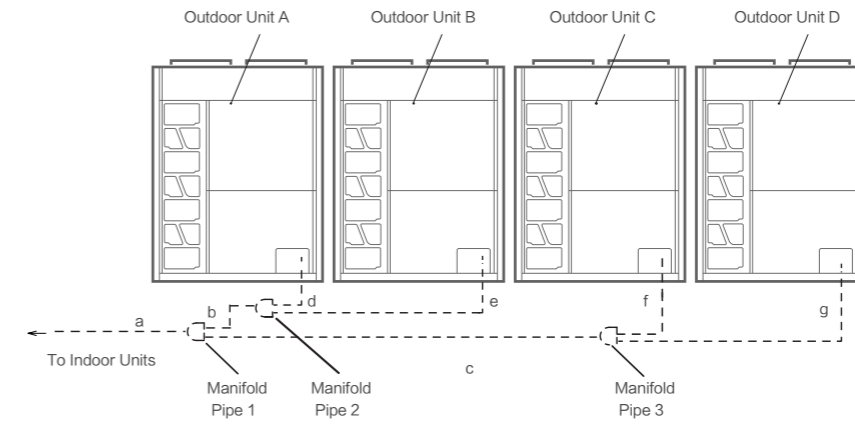

Standard Combination

Outdoor Unit	AVWT-290-422CKFSE	AVWT-444-544CKFSE	AVWT-552-634CKFSE	AVWT-654-696CKFSE	AVWT-714-816CKFSE	AVWT-824-886CKFSE	AVWT-908-1088CKFSE
Manifold Pipe1	HFQ-M32F	HFQ-M462F	HFQ-M462F	HFQ-M682F	HFQ-M682F	HFQ-M682F	HFQ-M682F
Manifold Pipe2	-	-	HFQ-M32F	HFQ-M32F	HFQ-M462F	HFQ-M462F	HFQ-M462F
Manifold Pipe3	-	-	-	-	-	HFQ-M32F	HFQ-M462F

High-efficiency Combination

Outdoor Unit	AVWT-152-228CKFSH	AVWT-250CKFSH	AVWT-268-364CKFSH	AVWT-386CKFSH	AVWT-402-420CKFSH	AVWT-438-456CKFSH	AVWT-478CKFSH
Manifold Pipe1	HFQ-M22F	HFQ-M32F	HFQ-M32F	HFQ-M32F	HFQ-M32F	HFQ-M462F	HFQ-M462F
Manifold Pipe2	-	-	HFQ-M22F	HFQ-M32F	HFQ-M22F	HFQ-M22F	HFQ-M32F
Manifold Pipe3	-	-	-	-	HFQ-M22F	HFQ-M22F	HFQ-M22F

### Branch Pipe (For indoor unit)

First Branch Pipe

Outdoor Unit HP	8 to 10	12 to 16	18 to 24	26 to 44	46 to 66	68 to 112
Branch Pipe	HFQ-102F	HFQ-162F	HFQ-242F	HFQ-302F	HFQ-462F	HFQ-682F

First Branch Pipe ~ Last Branch Pipe

Total Indoor Unit Hp	Lower than 6	6 to 8.99	9 to 11.99	12 to 15.99	16 to 17.99	18 to 25.99	26 to 33.99	34 to 45.99	46 to 58.99	59 to 68.99	Over 69
Gas ( mm )	15.88	19.05	22.2	25.4	28.6	28.6	31.75	38.1	41.3	44.5	50.8
Liquid ( mm )	9.53	9.53	9.53	12.7	12.7	15.88	19.05	19.05	22.2	22.2	25.4
Branch Pipe	HFQ-102F	HFQ-102F	HFQ-102F	HFQ-162F	HFQ-162F	HFQ-242F	HFQ-302F	HFQ-302F	HFQ-462F	HFQ-462F	HFQ-682F

Last Branch Pipe ~ Indoor Unit

Indoor Unit	Pipe Size ( Φmm )		Max. Liquid Pipe Length
	Gas Pipe	Liquid Pipe	
7kBTu/h~14kBTu/h	12.7	6.35*1	40
17kBTu/h~18kBTu/h	15.88	6.35*1	40
22kBTu/h~54kBTu/h	15.88	9.53	40
76kBTu/h	19.05	9.53	40
96kBTu/h	22.2	9.53	40

Notes 1. When liquid pipe length of indoor unit(07-18kBTu/h) is more than 15m, please change the liquid pipe dimension from Φ6.35 into Φ9.53.